

**Art.: 610**

SAMLEVEJLEDNING  
ASSEMBLY INSTRUCTIONS  
BAUANLEITUNG  
MONTAGE HANDLEIDING  
ISTRUZIONI DI MONTAGGIO  
NOTICE DE MONTAGE

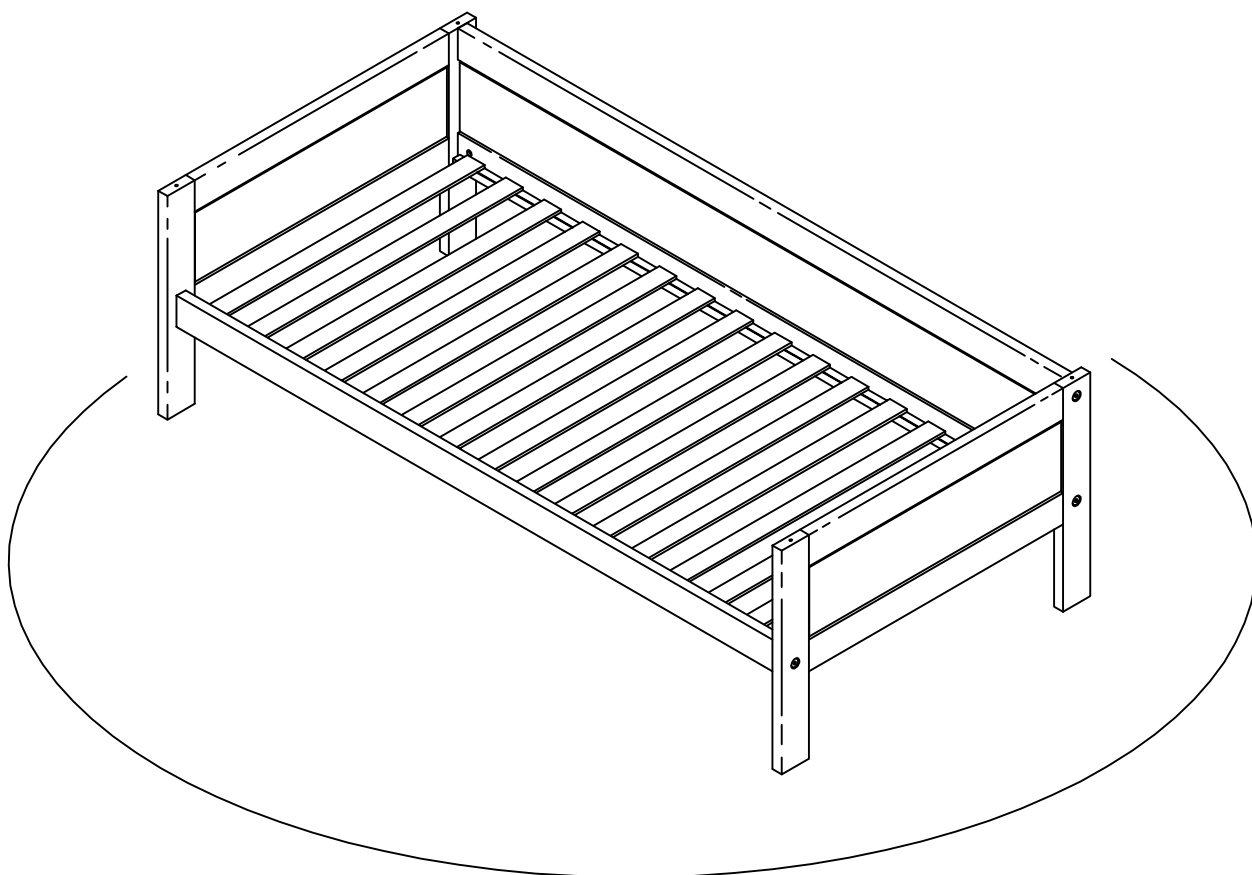

**VIGTIGT !    IMPORTANT !    WICHTIG !    BELANGRIJK !    IMPORTANTE !    IMPORTANT !**

DK / Før du starter. Læs venligst denne instruktion grundig igennem og opbevar denne til evt. senere brug. Sørg for at plastikposer ikke kommer i små børns hænder og vær sikker på, at der ikke er små børn i nærheden, under montagen, da der er små dele i pakken.

UK / Before you start. Please read instructions carefully and retain for future reference. Please dispose carefully of packing materials. Keep plastic bags away from small children. Ensure small children are kept clear during assembly as this pack contains small parts.

D / Bevor Sie anfangen, lesen Sie bitte diese Bauanleitung sorgfältig durch und bewahren Sie diese für späteren Gebrauch auf. Sichern Sie sich, dass die Plastiktüten nicht in den Händen von kleinen Kindern kommen, und auch dass keine kleinen Kinder beim aufbauen in der Nähe sind weil die Verpackung kleine Teile beinhaltet.

NL / Voordat u begint, leest u alstublieft de montage handleiding aandachtig door en bewaar deze zorgvuldig. Plastic verpakkingsmateriaal weghouden bij jonge kinderen. Wees er zeker van dat tijdens het monteren van het bed de kinderen op een veilige afstand zijn, omdat de verpakking kleine onderdelen bevat.

IT/ Prima di iniziare. Si prega di leggere attentamente le istruzioni e di conservarle per un uso successivo. Tenere lontano dalla portata dei bambini il pacchetto perché contiene piccole parti di assemblaggio e fare attenzione a non lasciarle in giro.

F/ Avant de commencer. Veuillez lire cette notice soigneusement et pensez à la garder pour une utilisation ultérieure. Veuillez à ne pas laisser les sachets plastiques accessibles aux enfants, et à éloigner les enfants pendant le montage car présence de petits objets dans les colis.

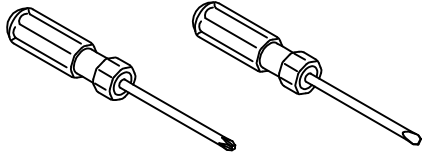
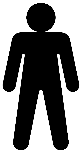

ART: 610  
Colli: 3 = 610A+B+C

**40610**

**10610A**

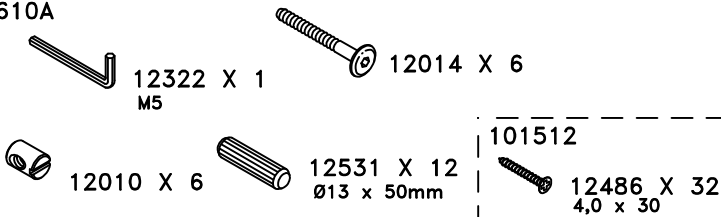

**10610B**

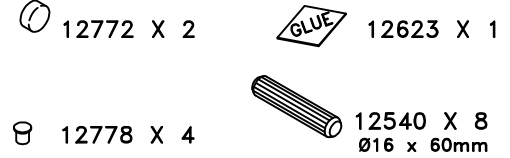

Fittings placed in 610A

**610-A**

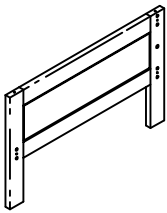

90610L X 1

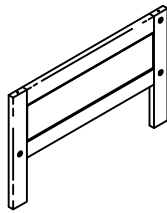

90610R X 1

**610-C**

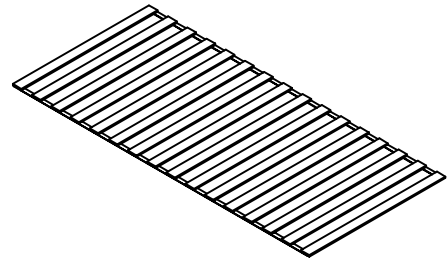

X 1

**610-B**

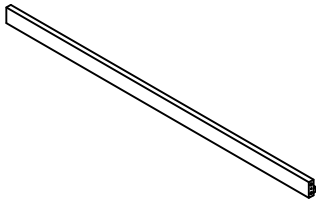

906104F X 1

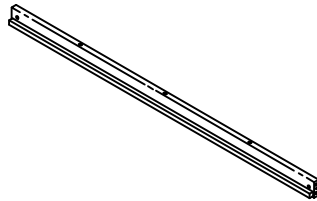

906104B X 1

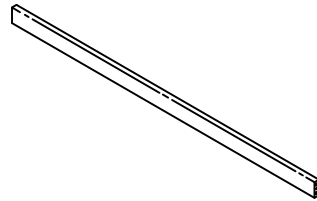

226101 X 1

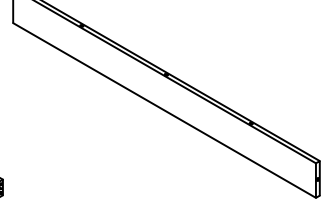

356103 X 1

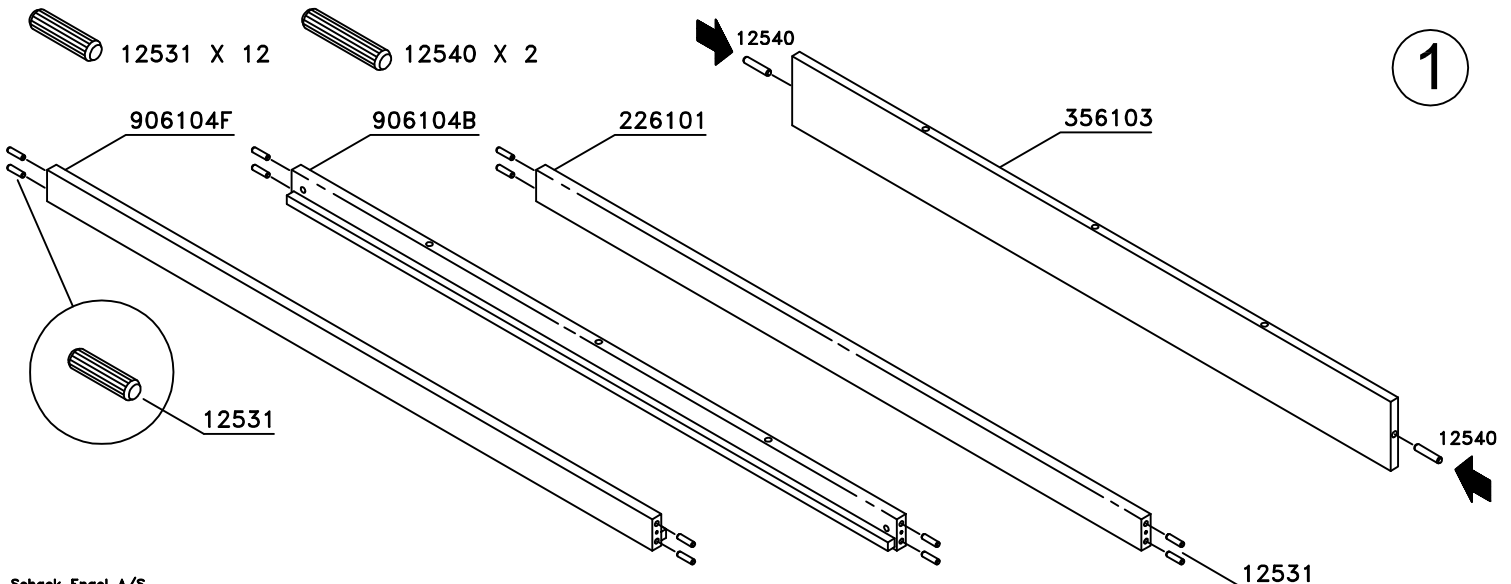

12540 X 6

2

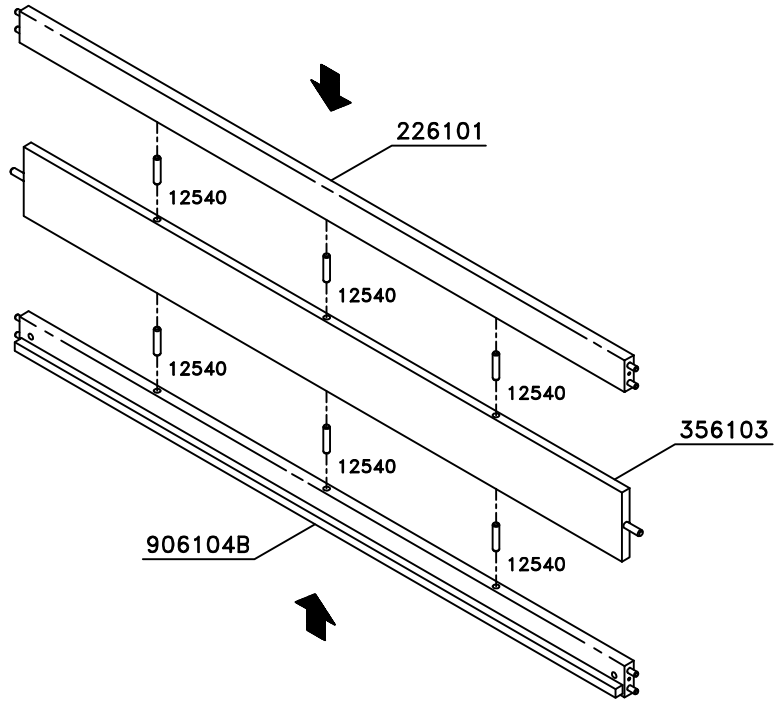

12014 X 6    12010 X 6    12772 X 2    12322 X 1 M5    12778 X 4

3

OBS!

DK / Møtrikken monteres i vandret position  
 UK / Aligning the barrel nuts.  
 D / Schraubenmutter horizontal einstecken  
 NL / De moer horizontaal erin steken.  
 IT / Il dado va montato in posizione orizzontale  
 F / L 'écrou doit être monté en position horizontale.

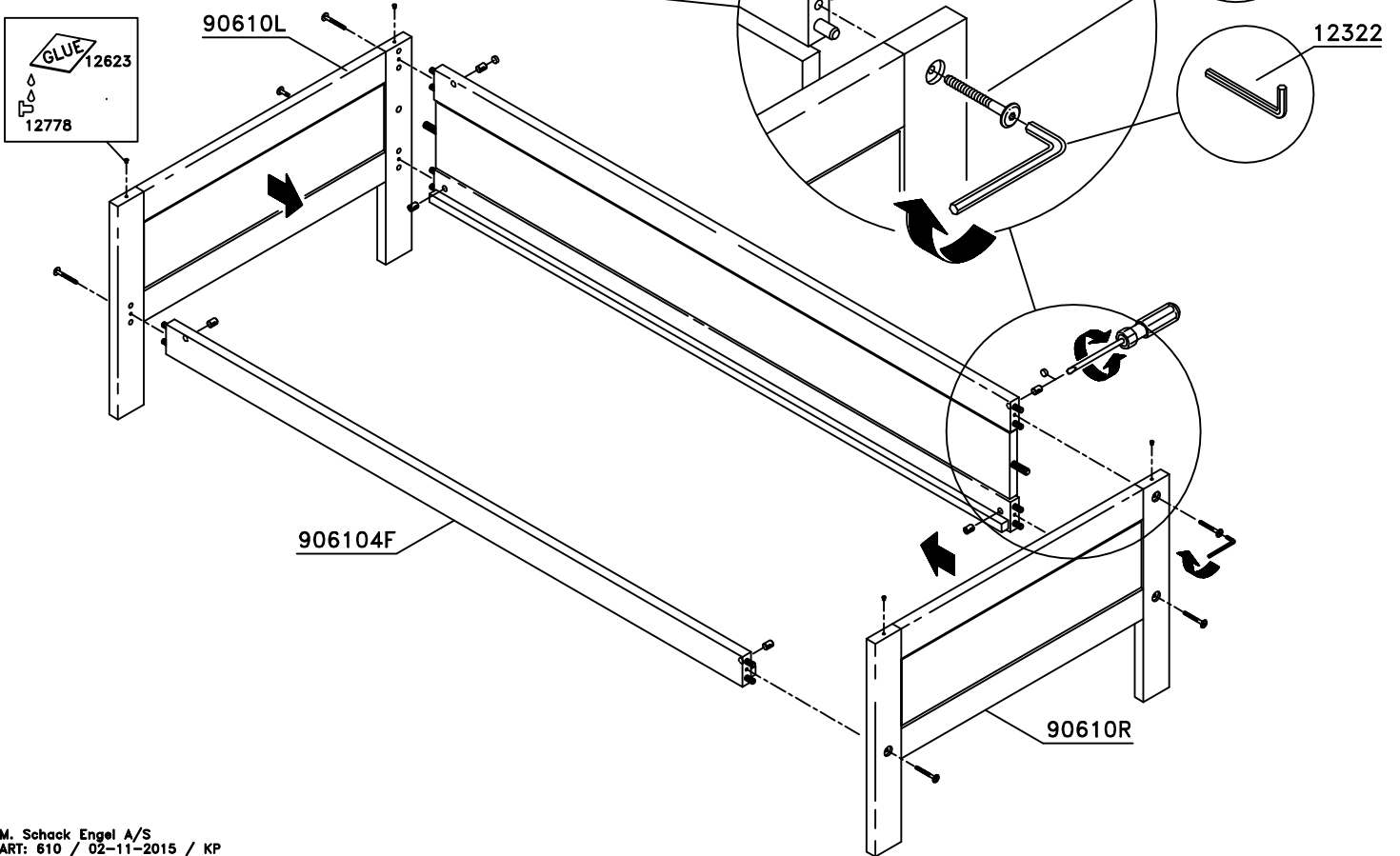

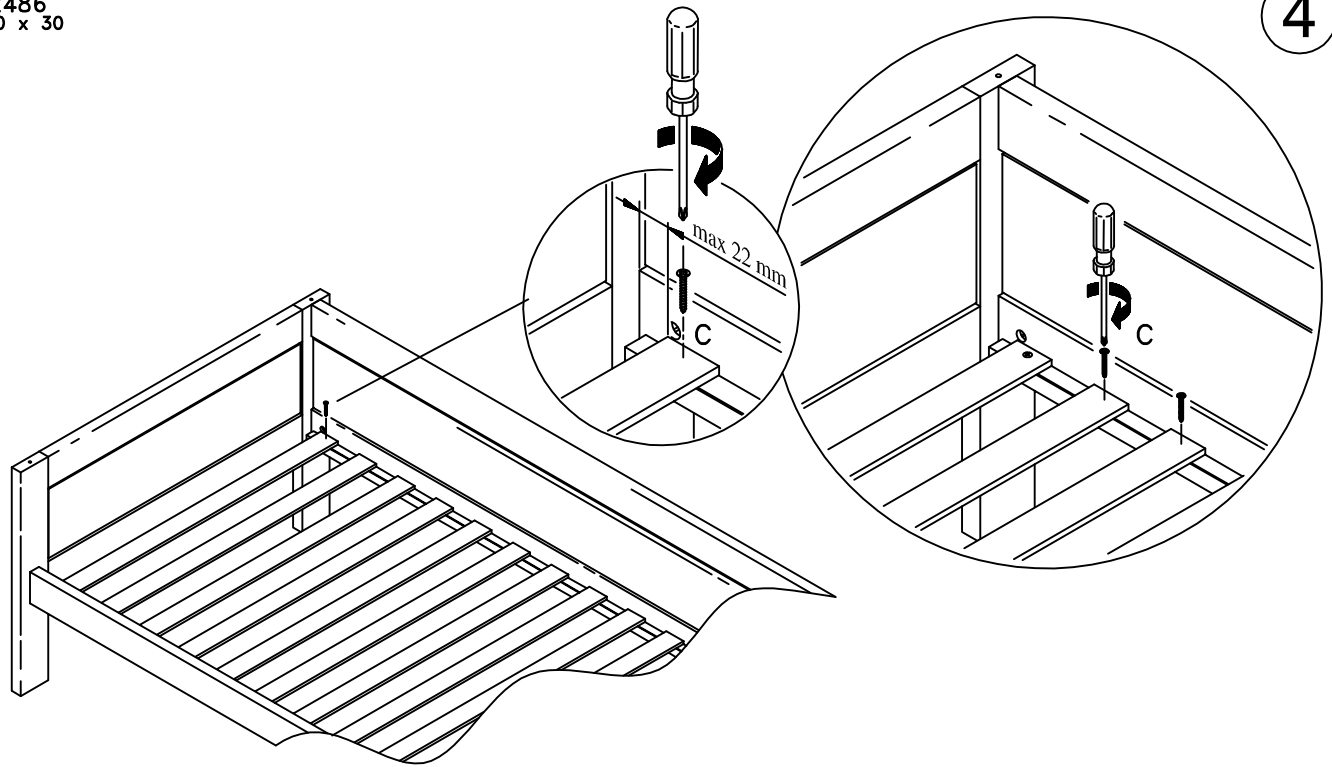

EN 747-1:2012 - BS EN 747-1:2012  
EN 747-2:2012 - BS EN 747-2:2012

DK / Madras mål: Vi anbefaler til denne seng 200 cm x 90 cm

UK / Mattress size: The recommended mattress to be used with this bed should measure 200cm x 90 cm

D / : Das Matratzenmass was wir für dieses Bett empfehlen hat das Mass 200 cm x 90 cm

NL / Matrasafmetingen : De matras welke wij u adviseren in combinatie met dit bed heeft de afmetingen 200cm x 90 cm

IT / Dimensioni materasso: consigliamo per questo letto misure di 200 cm x 90 cm

F / Dimensions matelas: Nous recommandons pour ce lit un matelas avec les dimensions 200 cm x 90 cm

#### DK / PLEJE OG SIKKERHED

**DK / Vigtigt at denne vejledning bliver gemt til evt. senere brug. Læs omhyggeligt.**

Kontroller jævnligt at alle beslagene er fastspændte og at intet er beskadiget, så man ikke kan komme til skade. Ved manglende eller beskadigede dele må sengen ikke bruges. For at undgå børnene bliver klemt fast mellem toppen af sengehesten og vægen, må afstanden ikke overstige 75 mm eller skal den være større end 230 mm. Vær opmærksom på at børn kan blive kvælt i dele som reb, snore, liner, selser og bæltter som er fastgjort eller hængt på etage / højsengen. Sengen bør ikke benyttes som legeplads, da uforsigtig leg kan medføre ødelæggelse på sengesiderne og dermed skade barnet. Der må ikke bruges skuremidler eller stærke rengøringsartikler til at rengøre produktet. Benyt en fugtig klud og tør efter med en tør klud

#### UK / MAINTENANCE AND SAFETY

**UK / Important to save these information for later use. Read Carefully.**

Periodically check all fixings to ensure none have come loose and regularly inspect for damage which may cause injury. Do not use the bed if any structural part is broken or missing. Children can become trapped between the bed and the wall. To avoid risk of serious injury the distance between the top safety barrier and the wall shall not exceed 75 mm or shall be more than 230mm. Be aware that children can strangle in items such as ropes, strings, cords, harnesses and belts attached to or hung on a bunk / high bed. Bouncing on, or using this bed in a manner other than it's intended purpose could damage the frame or cause serious injury to your child. Never clean your bed with abrasive cleaners or strong detergents. Clean by wiping with a damp cloth and drying with a soft cloth.

#### D / PFLEGE UND SICHERHEIT

**D / Wichtig ist, dass diese Anleitung für spätere Benutzung aufbewahrt wird.**

Kontrollieren Sie periodisch alle Beschläge um sicher zu sein, dass keine Beschläge lose sind und prüfen Sie regelmässig nach ob etwas Beschädigt ist, sodass niemand zu Schaden kommt. Verwenden Sie das Bett nicht, wenn Teile gebrochen sind oder fehlen. Kinder können zwischen dem Bett und der Wand eingeklemmt werden. Um ernste Verletzungsgefahr zu vermeiden, darf der Abstand zwischen der Oberkante der Absturzicherung und der Wand höchstens 75 mm betragen oder der Abstand muss größer als 230 mm sein. Achten Sie darauf daß sich Kinder mit Gegenständen z.B. Stricken, Schnüren, Kordeln, Gurten, Bändern die an einem Etagen- oder Hochbett befestigt oder angebracht sind, strangulieren können.

Um das Bett zu reinigen, bitte keine Schleifmittel oder stärkere Reinigungsmittel benutzen. Sondern nehmen Sie ein feuchtes Tuch und trocknen Sie anschliessend mit einem trockenen weichen Tuch nach.

#### NL / ONDERHOUD EN VEILIGHEID

**NL / BELANGRIJK, ZORGVULDIG DOORLEZEN EN BEWAREN ALS NASLAGWERK.**

Controleer regelmatig alle bevestigingspunten om er zeker van te zijn dat er niets is losgeraakt. Controleer ook regelmatig op beschadigingen welke eventueel verwondingen kunnen veroorzaken. Gebruik het bed niet als er een essentieel onderdeel is gebroken of mist. Kinderen kunnen beklemd raken tussen het bed en de muur. Om het risico op ernstige verwondingen te voorkomen, mag de afstand tussen de bovenkant van de uitvalbeveiliging en de muur niet groter zijn dan 75 mm of de afstand moet groter zijn dan 230 mm. Opgelet met artikelen, zoals touwen, koorden, riemen, draden, snoeren, die aan het bed hangen of bevestigd zijn. Uw kind kan zich hiermee wurgen. Springen op, of enig ander onjuist gebruik dan waar dit bed voor bedoeld is, kan schade veroorzaken aan het frame wat kan leiden tot ernstige verwondingen bij uw kind. Voor het schoonmaken van het bed dient u GEEN gebruik te maken van agressieve of sterk zuiverende schoonmaakmiddelen. Gebruik alleen een vochtige doek en droog na met een zachte doek.

#### IT / MANUTENZIONE E SICUREZZA

**IT / IMPORTANT LEGGERE ATTENTAMENTE LE ISTRUZIONI DI SEGUITO, PER UN CORRETTO USO SUCCESSIVO DEL PRODOTTO**

Controllare regolarmente che tutti i componenti siano ben chiusi e che nulla sia danneggiato, per evitare di farsi male. Infatti non è possibile dormire bene se vi sono pezzi mancanti o danneggiati. Per impedire a bambini di rimanere incastrati tra la parte superiore della seduta laterale e la parete, la distanza non deve superare i 75 mm oppure dovrà essere maggiore di 230 mm. Bisogna essere consapevoli del fatto che i bambini potrebbero soffocare con alcune parti come funi, corde, imbracature e cinture attaccate o appese al pavimento / letto alto. Il letto non deve essere usato come un parco giochi: una piccola disattenzione può causare danni al telaio e quindi danneggiare il bambino. Non utilizzare detersivi abrasivi o aggressivi per pulire il prodotto. Usare un panno umido e asciugare con un panno asciutto.

#### F / TRAITEMENT ET SECURITE

**F / IMPORTANT DE BIEN GARDER CETTE NOTICE POUR UNE UTILISATION ULTERIEURE ÉVENTUELLE. A LIRE MINUTIEUSEMENT.**

Vérifier à intervalles réguliers que toutes les ferrures sont bien fixées et que rien n'est abimé afin de ne pas se blesser. Si certaines parties sont manquantes ou abimées, le lit ne doit pas être utilisé. Par mesure de sécurité, il est recommandé de laisser une distance inférieure à 75 mm entre l'arrière du lit et le mur, ou bien une distance supérieure à 230 mm. Attention aux éventuels cordes, sangles, bretelles ou ceintures attachées sur le lit à l'étage. Le lit ne doit pas servir de lieu pour jouer, car un jeu imprudent peut provoquer des dégâts sur les côtés du lit et ainsi blesser l'enfant. Ne pas utiliser de produits de nettoyage puissants ou à récurer. Utiliser un chiffon mouillé et sécher ensuite avec un chiffon sec.



**LIFETIME**  
KIDSROOMS

Samlevejledning  
Assembly Instructions  
Bauanleitung  
Montage handleiding  
Notice de montage  
Istruzioni di montaggio

**Art: 667**

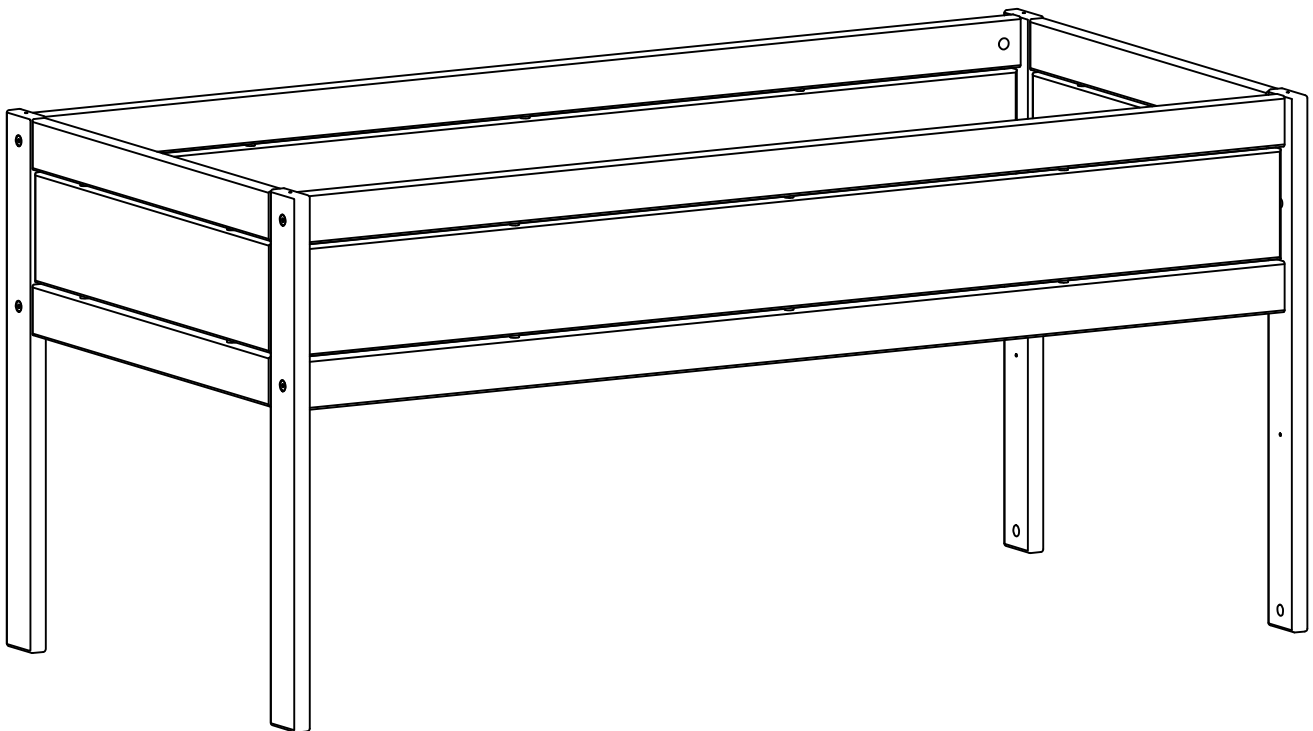

**VIGTIGT !****IMPORTANT !****WICHTIG !****BELANGRIJK !**

DK Før du starter. Læs venligst denne instruktion grundigt igennem og opbevar denne til evt senere brug. Sørg for at plastikposer ikke kommer i små børns hænder og vær sikker på, at der ikke er små børn i nærheden, under montagen, da der er små dele i pakken.

UK Before you start. Please read instructions carefully and retain for future reference. Please dispose carefully of packing materials. Keep plastic bags away from young children. Ensure young children are kept clear during assembly as this pack contains small parts.

D Bevor Sie anfangen lesen Sie bitte die Bauanleitung sorgfältig durch und bewahren Sie diese Anleitung auf. Versichern Sie sich, dass keine kleinen Kinder in der Nähe sind während Sie aufbauen weil die Verpackung kleinste Teile beinhaltet. Plastic Verpackungsteile daher bitte gleich wegwerfen.

NL Voordat u begint, lees a.u.b. de montage-instructie aandachtig door en bewaar deze zorgvuldig. Plastic verpakkingsmateriaal weghouden bij jonge kinderen. Wees er zeker van dat tijdens het monteren van het bed de kinderen op veilige afstand zijn omdat de verpakking kleine onderdelen bevat.

F Avant de commencer. Veuillez lire cette notice soigneusement et pensez à la garder pour une utilisation ultérieure. Veuillez à ne pas laisser les sachets plastiques accessibles aux enfants, et à éloigner les enfants pendant le montage car présence de petits objets dans les colis.

I Prima di iniziare. Si prega di leggere attentamente le istruzioni e di conservarle per un uso successivo. Tenere lontano dalla portata dei bambini il pacchetto perché contiene piccole parti di assemblaggio e fare attenzione a non lasciarle in giro.

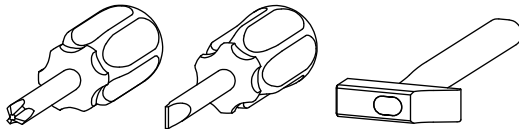
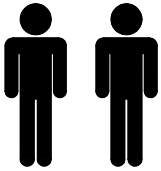

Art: 667 A + 667 B + 667 C

Colli: 3

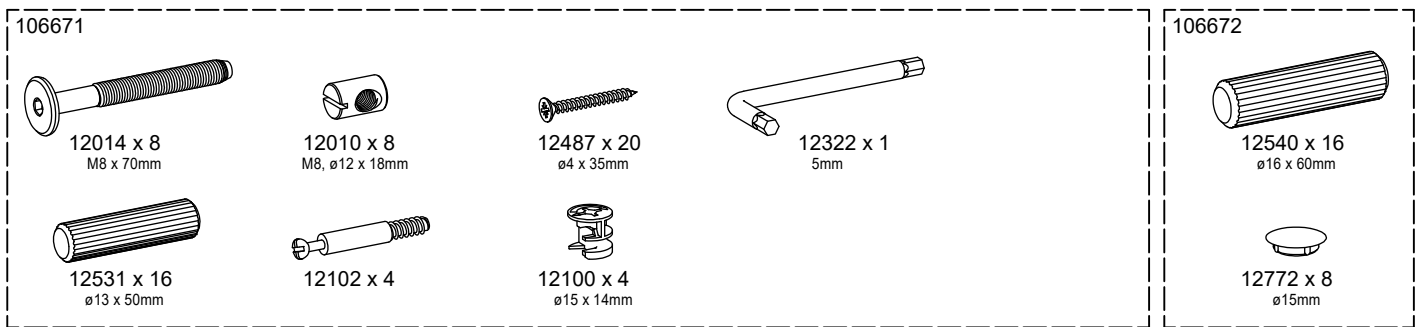

667 A

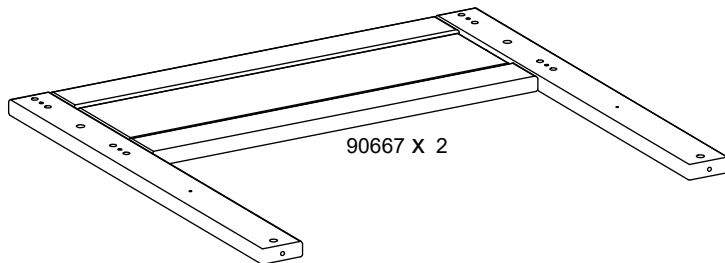

667 B

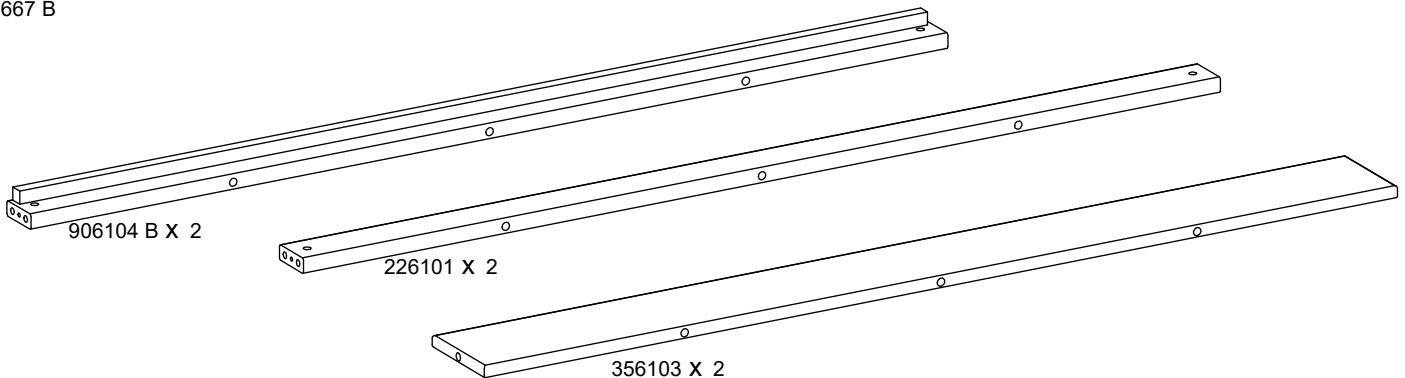

667 C

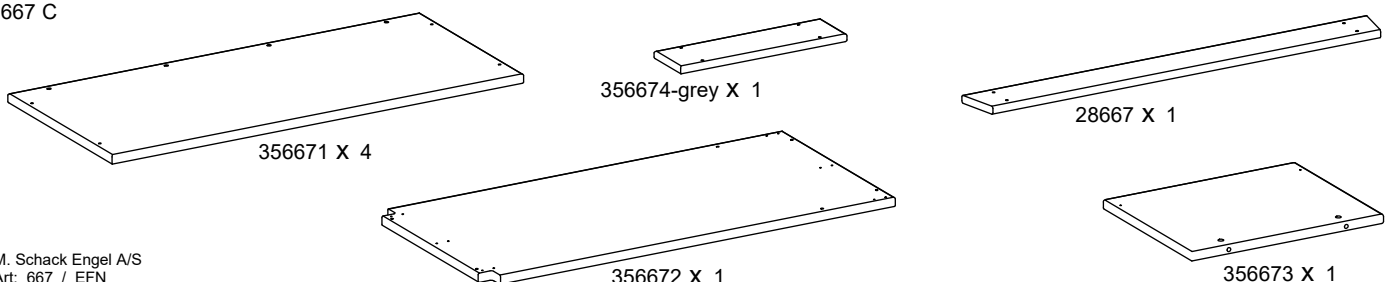

1

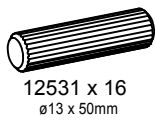

12531 x 16  
ø13 x 50mm

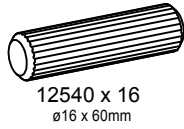

12540 x 16  
ø16 x 60mm

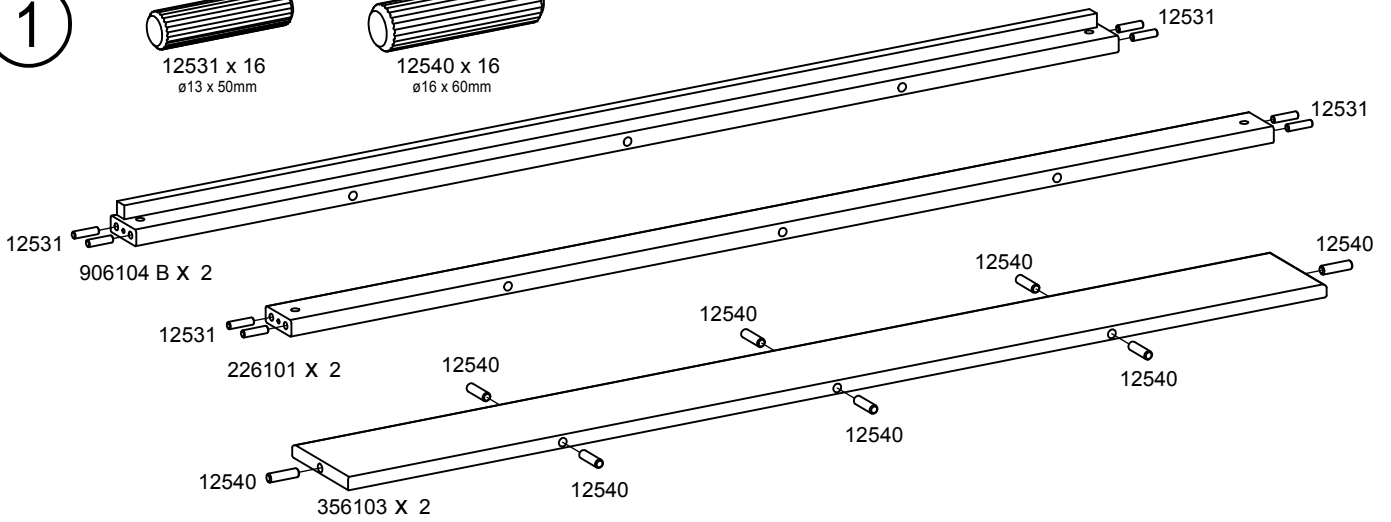

2

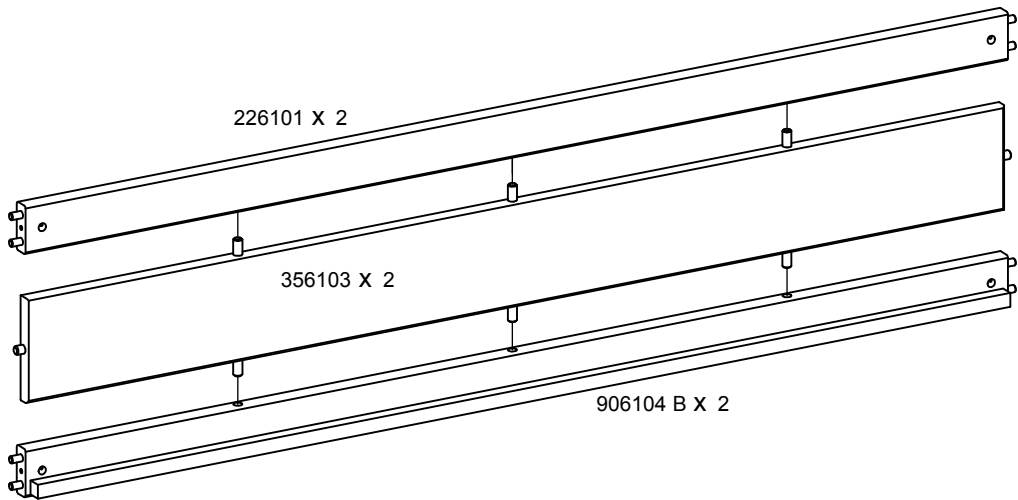

3



12014 x 8  
M8 x 70mm



12010 x 8  
M8, ø12 x 18mm

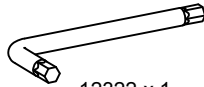

12322 x 1  
5mm

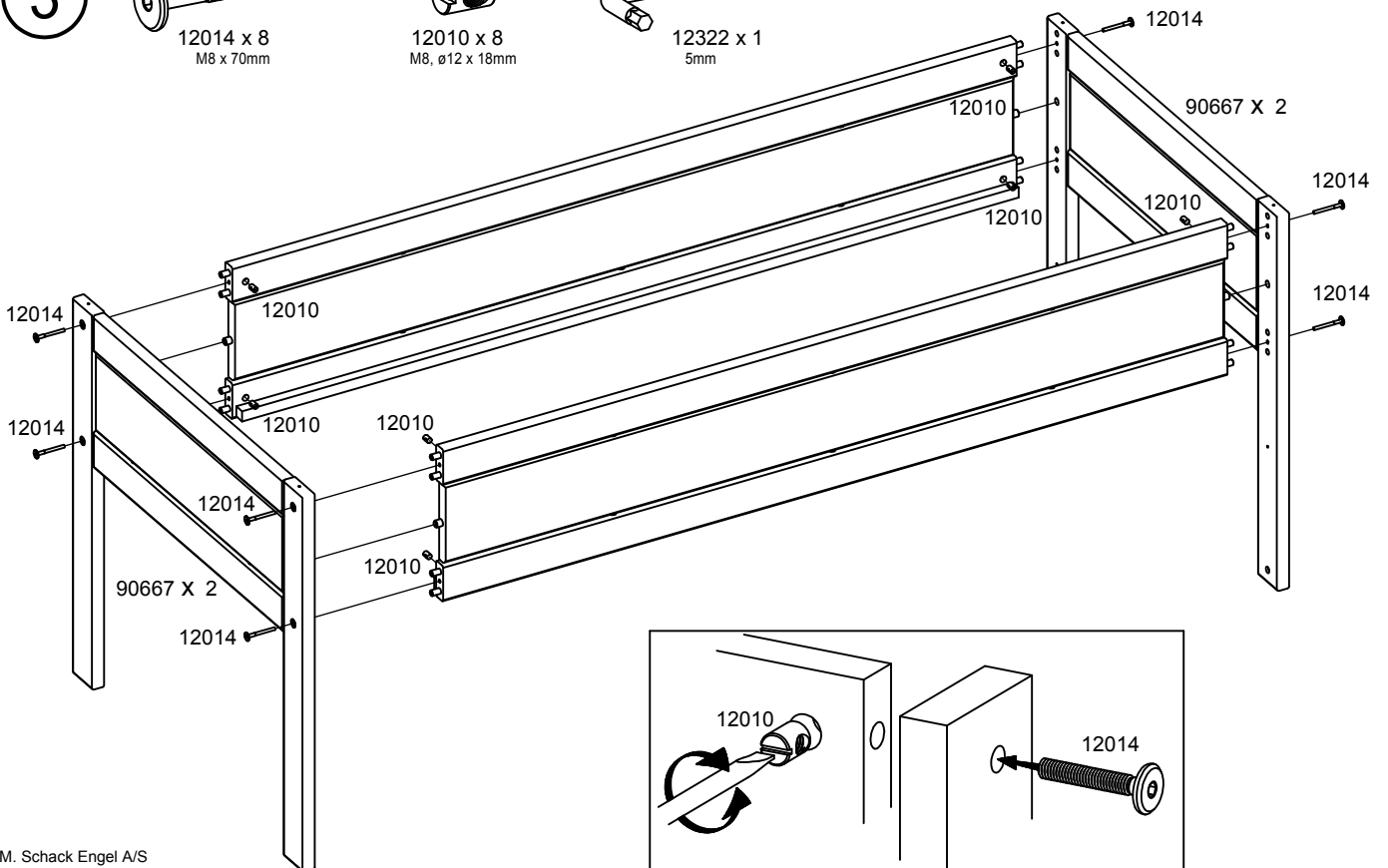

4



12487 x 20  
ø4 x 35mm



12772 x 8  
ø15mm

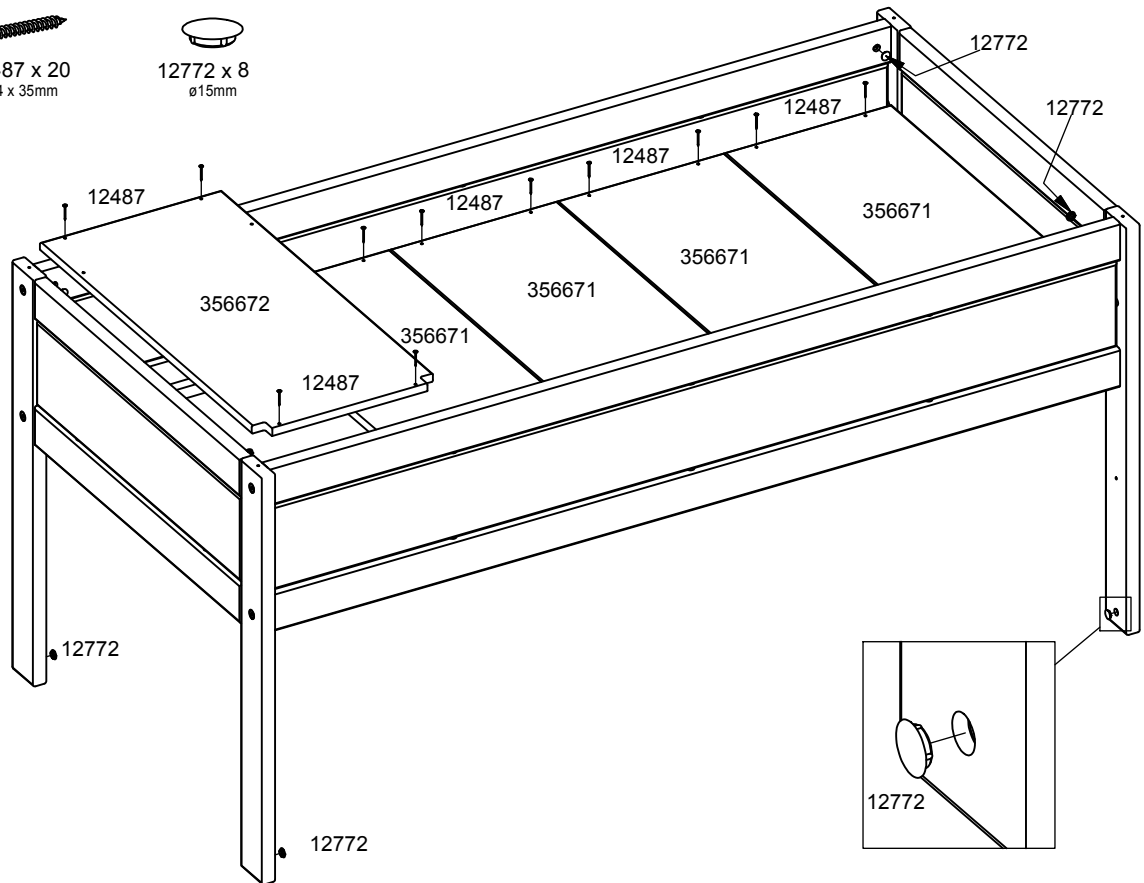

DK : Madrasmål: Vi anbefaler til denne seng 200 x 140cm x 12/14cm.

GB : Mattress size: The recommended mattress to be used with this bed should measure 200 x 90cm x 12/14cm.

NL : Das Matratzenmass was wir für dieses Bett empfehlen hat das Mass 200 x 90cm x 12/14cm.

D : Matrasafmetingen: De matras welke wij u adviseren in combinatie met dit bed heeft de afmetingen 200 x 90cm x 12/14cm.

IT : Dimensioni materasso: consigliamo per questo letto misure di 200cm x 90cm.

F : Dimensions matelas: Nous recommandons pour ce lit un matelas avec les dimensions 200cm x 90cm.

## DK I PLEJE OG SIKKERHED

Det er vigtigt at denne vejledning bliver gemt til evt. senere brug. Læs omhyggeligt.

Kontroller jævnligt at alle beslagene er fastspændte og at intet er beskadiget, så man ikke kan komme til skade. Ved manglende eller beskadigede dele må sengen ikke bruges. For at undgå at børnene bliver klemt fast mellem toppen af sengehesten og væggen, må afstanden ikke overstige 75mm eller også skal den være større end 230mm. Vær opmærksom på at børn kan blive kvalt i dele som reb, snore, liner, seler og bæltter som er fastgjort eller hængt på etage/ højsengen. Sengen bør ikke benyttes som legeplads, da uforsigtig leg kan medføre ødelæggelse på sengesiderne og dermed skade barnet. Der må ikke bruges skuremidler eller stærke rengøringsartikler til at rengøre produktet. Benyt en fugtig klud og tør efter med en tør klud.

## UK I MAINTENANCE AND SAFETY

It is important to save this information for later use. Read Carefully.

Periodically check all fixings to ensure none have come loose and regularly inspect for damage which may cause injury. Do not use the bed if any structural part is broken or missing. Children can become trapped between the bed and the wall. To avoid risk of serious injury the distance between the top safety barrier and the wall shall not exceed 75mm or shall be more than 230mm. Be aware that children can strangle in items such as ropes, strings, cords, harnesses and belts attached to or hung on a bunk / high bed. Bouncing on, or using this bed in a manner other than its intended purpose could damage the frame or cause serious injury to your child. Never clean your bed with abrasive cleaners or strong detergents. Clean by wiping with a damp cloth and drying with a soft cloth.

## D I PFLEGE UND SICHERHEIT

Wichtig ist, dass diese Anleitung für spätere Benutzung aufbewahrt wird.

Kontrollieren Sie periodisch alle Beschläge um sicher zu sein, dass keine Beschläge lose sind und prüfen Sie regelmässig nach ob etwas Beschädigt ist, sodass niemand zu Schaden kommt. Verwenden Sie das Bett nicht, wenn Teile gebrochen sind oder fehlen. Kinder können zwischen dem Bett und der Wand eingeklemmt werden. Um ernste Verletzungsgefahr zu vermeiden, darf der Abstand zwischen der Oberkante der Absturzsisicherung und der Wand höchstens 75mm betragen oder der Abstand muss größer als 230mm sein. Achten Sie darauf daß sich Kinder mit Gegenständen z.B. Stricken, Schnüren, Kordeln, Gurten, Bändern die an einem Etage- oder Hochbett befestigt oder angebracht sind, strangulieren können.

Um das Bett zu reinigen, bitte keine Schleifmittel oder stärkere Reinigungsmittel benutzen. Sondern nehmen Sie ein feuchtes Tuch und trocknen Sie anschließend mit einem trockenen weichen Tuch nach.

## NL I ONDERHOUD EN VEILIGHEID

Belangrijk, zorgvuldig doorlezen en bewaren als naslagwerk.

Controleer regelmatig alle bevestigingspunten om er zeker van te zijn dat er niets is losgeraakt. Controleer ook regelmatig op beschadigingen welke eventueel verwondingen kunnen veroorzaken. Gebruik het bed niet als er een essentieel onderdeel is gebroken of mist. Kinderen kunnen beklemd raken tussen het bed en de muur. Om het risico op ernstige verwondingen te voorkomen, mag de afstand tussen de bovenkant van de uitvalbeveiliging en de muur niet groter zijn dan 75mm of de afstand moet groter zijn dan 230mm. Opgelet met artikelen, zoals touwen, koorden, riemen, draden, snoeren, die aan het bed hangen of bevestigd zijn. Uw kind kan zich hiermee wurgen. Springen op, of enig ander onjuist gebruik dan waar dit bed voor bedoeld is, kan schade veroorzaken aan het frame wat kan leiden tot ernstige verwondingen bij uw kind.

Voor het schoonmaken van het bed dient u GEEN gebruik te maken van agressieve of sterk zuiverende schoonmaakmiddelen. Gebruik alleen een vochtige doek en droog na met een zachte doek.

## IT I MANUTENZIONE E SICUREZZA

E' importante leggere attentamente le istruzioni di seguito, per un corretto uso successivo del prodotto.

Controllare regolarmente che tutti i componenti siano ben chiusi e che nulla sia danneggiato, per evitare di farsi male. Infatti non è possibile dormire bene se vi sono pezzi mancanti o danneggiati. Per impedire ai bambini di rimanere incastrati tra la parte superiore della seduta laterale e la parete, la distanza non deve superare i 75 mm oppure dovrà essere maggiore di 230 mm. Bisogna essere consapevoli del fatto che i bambini potrebbero soffocare con alcune parti come funi, corde, imbracature e cinture attaccate o appese al pavimento / letto alto. Il letto non deve essere usato come un parco giochi: una piccola disattenzione può causare danni al telaio e quindi danneggiare il bambino.

Non utilizzare detersivi abrasivi o aggressivi per pulire il prodotto. Usare un panno umido e asciugare con un panno asciutto.

## F I TRAITEMENT ET SECURITE

Important de bien garder cette notice pour une utilisation ultérieure éventuelle. A lire minutieusement.

Vérifier à intervalles réguliers que toutes les ferrures sont bien fixées et que rien n'est abîmé afin de ne pas se blesser. Si certaines parties sont manquantes ou abîmées, le lit ne doit pas être utilisé. Par mesure de sécurité, il est recommandé de laisser une distance inférieure à 75 mm entre l'arrière du lit et le mur, ou bien une distance supérieure à 230 mm. Attention aux éventuels cordes, sangles, bretelles ou ceintures attachées sur le lit à l'étage. Le lit ne doit pas servir de lieu pour jouer, car un jeu imprudent peut provoquer des dégâts sur les côtés du lit et ainsi blesser l'enfant.

Ne pas utiliser de produits de nettoyage puissants ou à récurer. Utiliser un chiffon mouillé et sécher ensuite avec un chiffon sec.



**Art.: 4623**

SAMLEVEJLEDNING  
ASSEMBLY INSTRUCTIONS  
BAUANLEITUNG  
MONTAGE HANDLEIDING  
ISTRUZIONI DI MONTAGGIO  
NOTICE DE MONTAGE

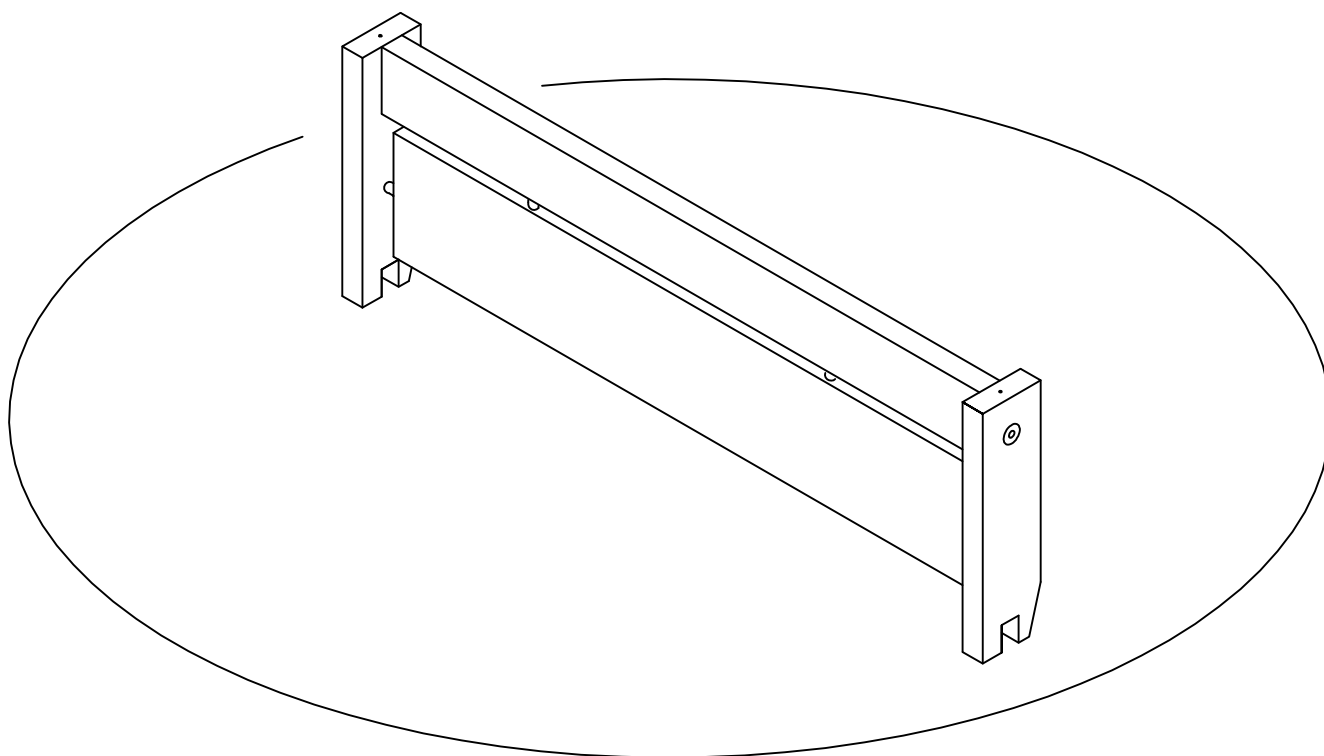

**VIGTIGT !    IMPORTANT !    WICHTIG !    BELANGRIJK !    IMPORTANTE !    IMPORTANT !**

DK / Før du starter. Læs venligst denne instruktion grundigt igennem og opbevar denne til evt. senere brug. Sørg for at plastikposer ikke kommer i små børns hænder og vær sikker på, at der ikke er små børn i nærheden, under montagen, da der er små dele i pakken.

UK / Before you start. Please read instructions carefully and retain for future reference. Please dispose carefully of packing materials. Keep plastic bags away from small children. Ensure small children are kept clear during assembly as this pack contains small parts.

D / Bevor Sie anfangen, lesen Sie bitte diese Bauanleitung sorgfältig durch und bewahren Sie diese für späteren Gebrauch auf. Sichern Sie sich, dass die Plastiktüten nicht in den Händen von kleinen Kindern kommen, und auch dass keine kleinen Kinder beim aufbauen in der Nähe sind weil die Verpackung kleine Teile beinhaltet.

NL / Voordat u begint, leest u alstublieft de montage handleiding aandachtig door en bewaar deze zorgvuldig. Plastic verpakkingsmateriaal weghouden bij jonge kinderen. Wees er zeker van dat tijdens het monteren van het bed de kinderen op een veilige afstand zijn, omdat de verpakking kleine onderdelen bevat.

IT/ Prima di iniziare. Si prega di leggere attentamente le istruzioni e di conservarle per un uso successivo. Tenere lontano dalla portata dei bambini il pacchetto perché contiene piccole parti di assemblaggio e fare attenzione a non lasciarle in giro.

F/ Avant de commencer. Veuillez lire cette notice soigneusement et pensez à la garder pour une utilisation ultérieure. Veillez à ne pas laisser les sachets plastiques accessibles aux enfants, et à éloigner les enfants pendant le montage car présence de petits objets dans les colis.

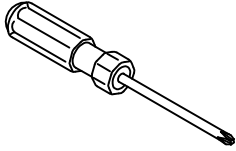
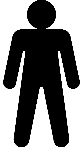

12623 - PLACED IN 610A

ART: 4623  
Colli: 1 = 4623

**10627A**

- 12010 x 2
- 12014 x 2
- 12410 X 2
- 12461 X 4  
4,0X20
- 12531 x 4  
13x50
- 12465 x 2  
4,0x40
- 12478 x 1  
4,5x50

**10627B**

- 12540 x 4  
16X60
- 12772 x 2
- 12778 X 2

**4623**

- 3562051 x 1
- 21624L x 1
- 2262051 x 1
- 21624R x 1

1

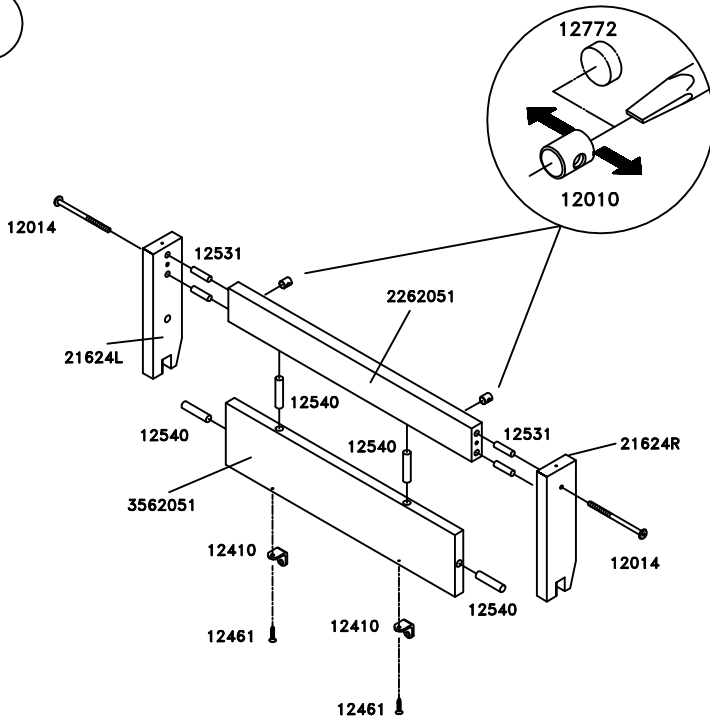

2

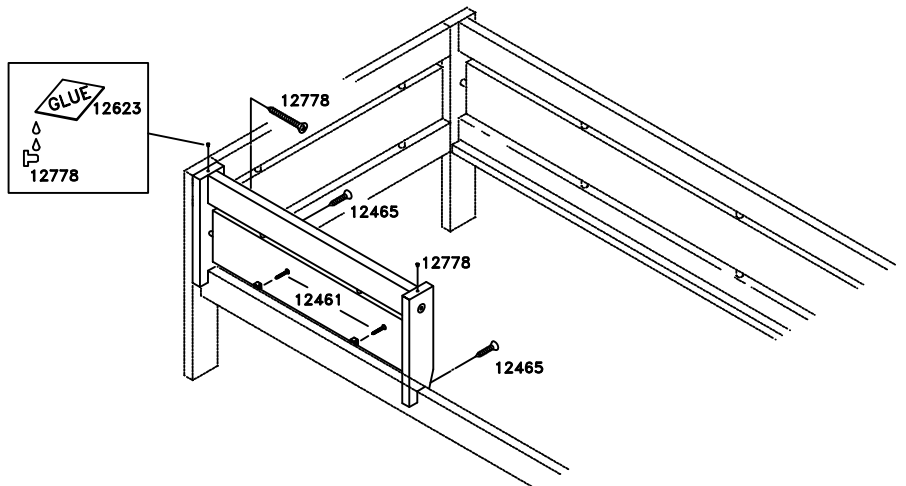



**LIFETIME**  
KIDSROOMS

Samlevejledning  
Assembly Instructions  
Bauanleitung  
Montage handleiding  
Notice de montage  
Istruzioni di montaggio

**Art: 191**

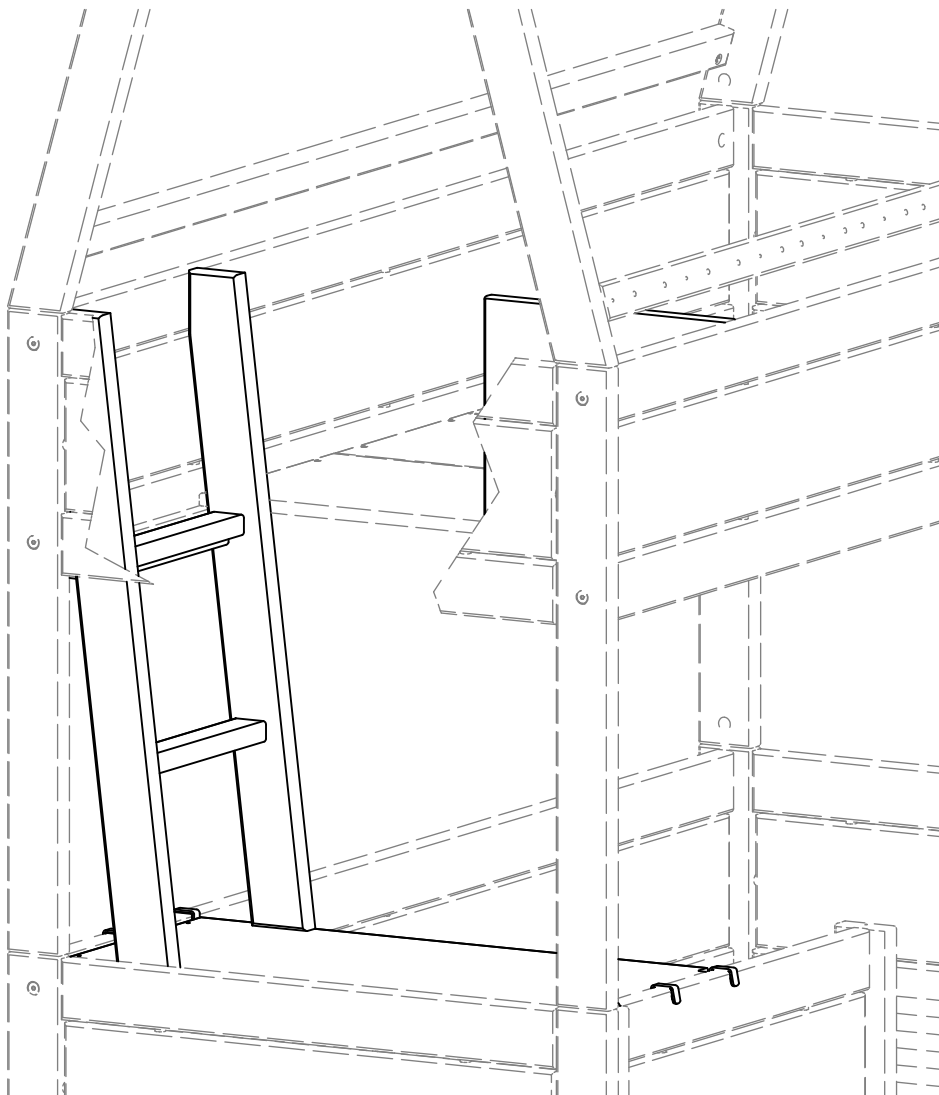

# VIGTIGT! IMPORTANT! WICHTIG! BELANGRIJK! IMPORTANT! IMPORTANTE!

- DK Før du starter. Læs venligst denne instruktion grundigt igennem og opbevar denne til evt senere brug. Sørg for at plastikposer ikke kommer i små børns hænder og vær sikker på, at der ikke er små børn i nærheden, under montagen, da der er små dele i pakken.
- UK Before you start. Please read instructions carefully and retain for future reference. Please dispose carefully of packing materials. Keep plastic bags away from young children. Ensure young children are kept clear during assembly as this pack contains small parts.
- D Bevor Sie anfangen lesen Sie bitte die Bauanleitung sorgfältig durch und bewahren Sie diese Anleitung auf. Versichern Sie sich, dass keine kleinen Kinder in der Nähe sind während Sie aufbauen weil die Verpackung kleinste Teile beinhaltet. Plastic Verpackungsteile daher bitte gleich wegwerfen.
- NL Voordat u begint, lees a.u.b. de montage-instructie aandachtig door en bewaar deze zorgvuldig. Plastic verpakkingsmateriaal weghouden bij jonge kinderen. Wees er zeker van dat tijdens het monteren van het bed de kinderen op veilige afstand zijn omdat de verpakking kleine onderdelen bevat.
- F Avant de commencer. Veuillez lire cette notice soigneusement et pensez à la garder pour une utilisation ultérieure. Veuillez à ne pas laisser les sachets plastiques accessibles aux enfants, et à éloigner les enfants pendant le montage car présence de petits objets dans les colis.
- I Prima di iniziare. Si prega di leggere attentamente le istruzioni e di conservarle per un uso successivo. Tenere lontano dalla portata dei bambini il pacchetto perché contiene piccole parti di assemblaggio e fare attenzione a non lasciarle in giro.

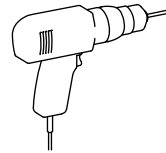
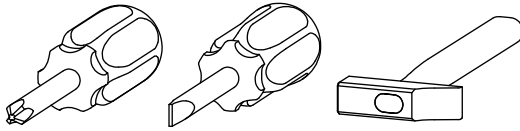
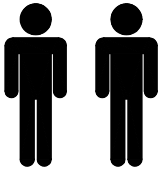

Art: 191  
Colli: 1

Art 40191

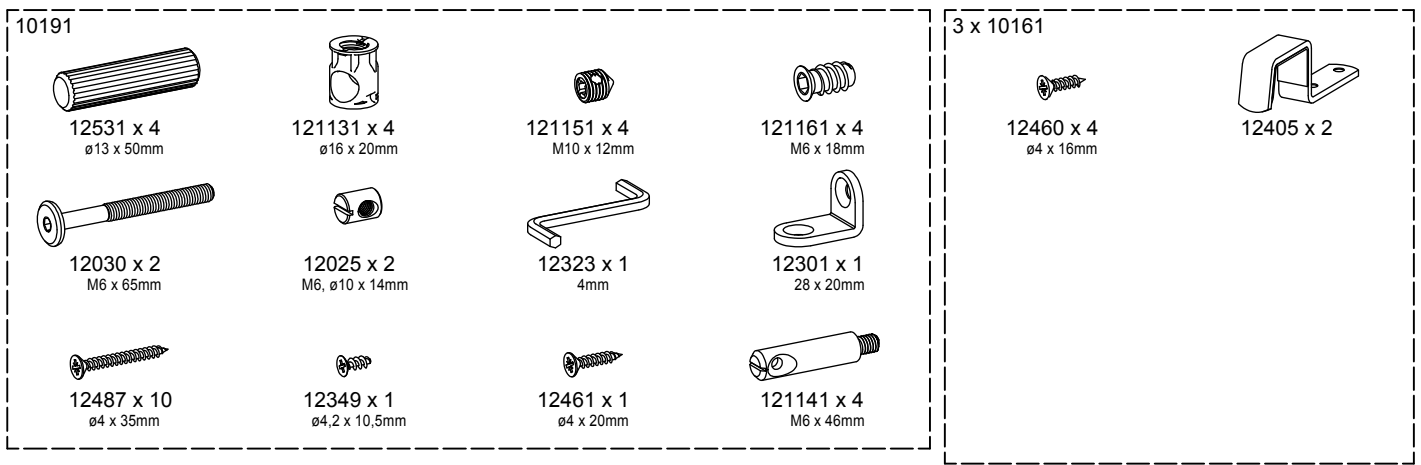

191

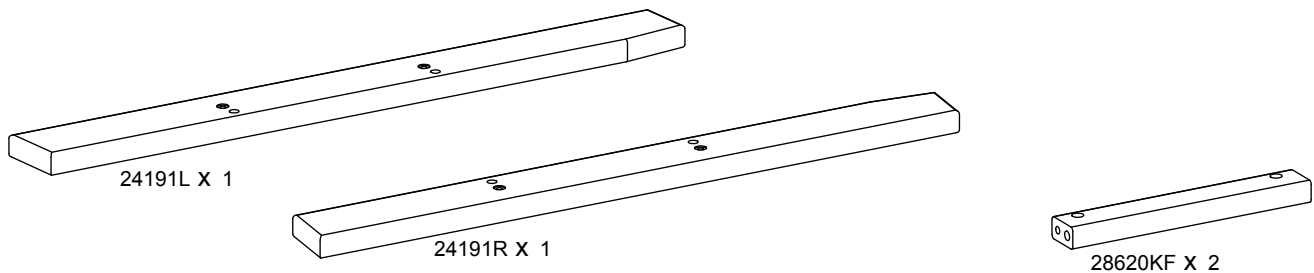

1

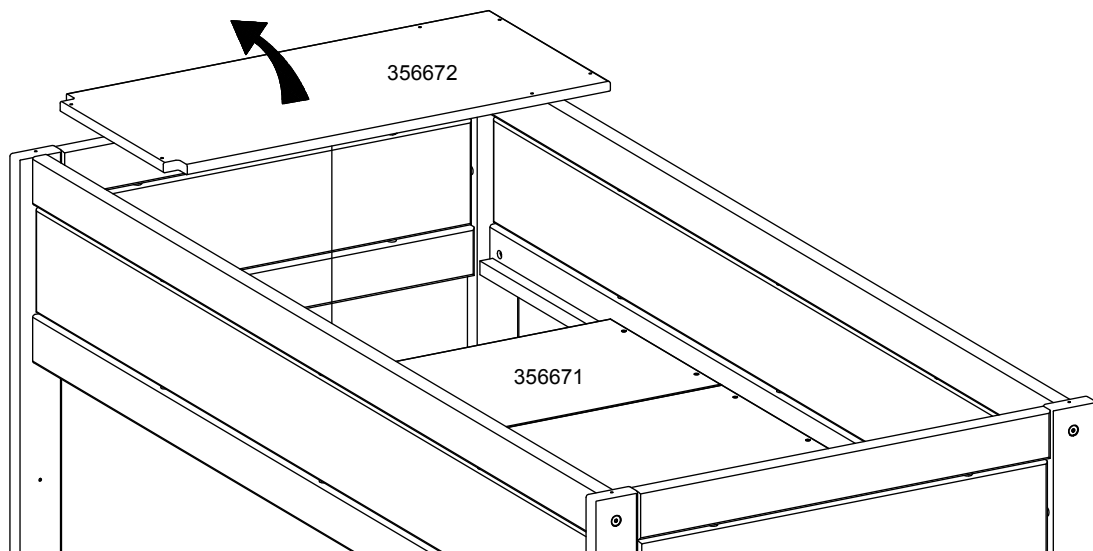

2



121141 x 4  
M6 x 46mm



121161 x 4  
M6 x 18mm

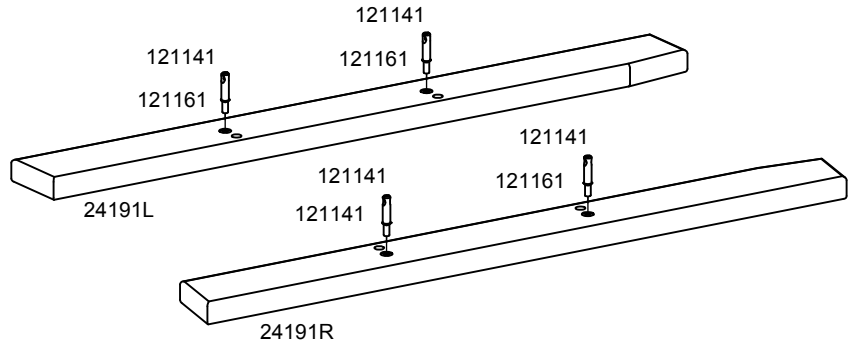
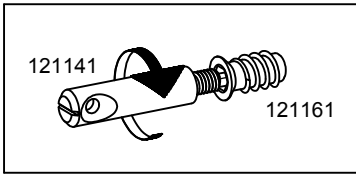

3



12531 x 4  
ø13 x 50mm

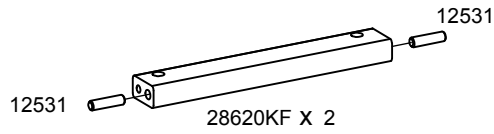

4



121131 x 4  
ø16 x 20mm



121151 x 4  
M10 x 12mm

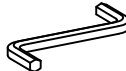

12323 x 1  
4mm

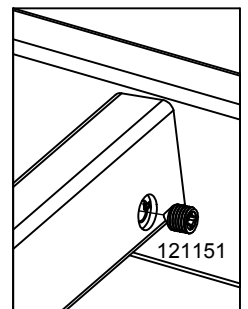
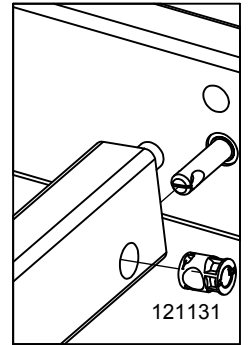
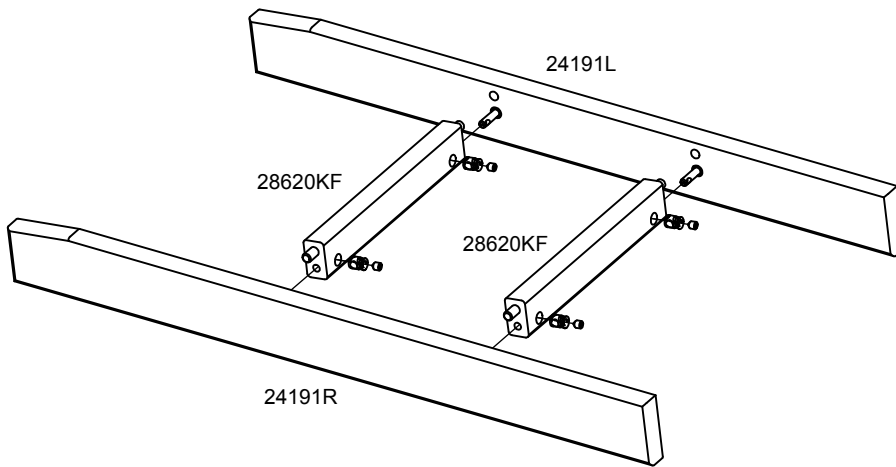

5



12405 x 6



12460 x 12  
ø4 x 16mm

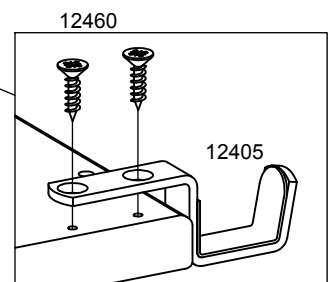
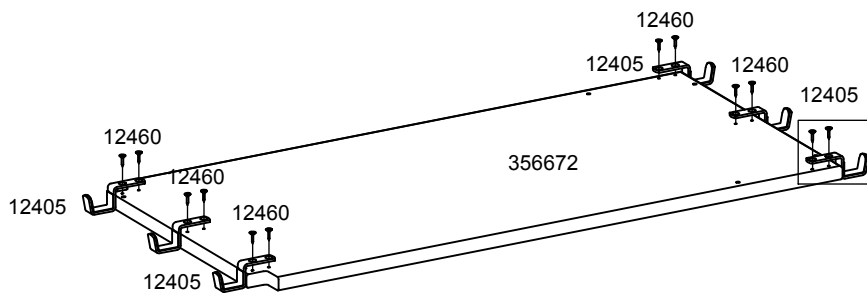

6

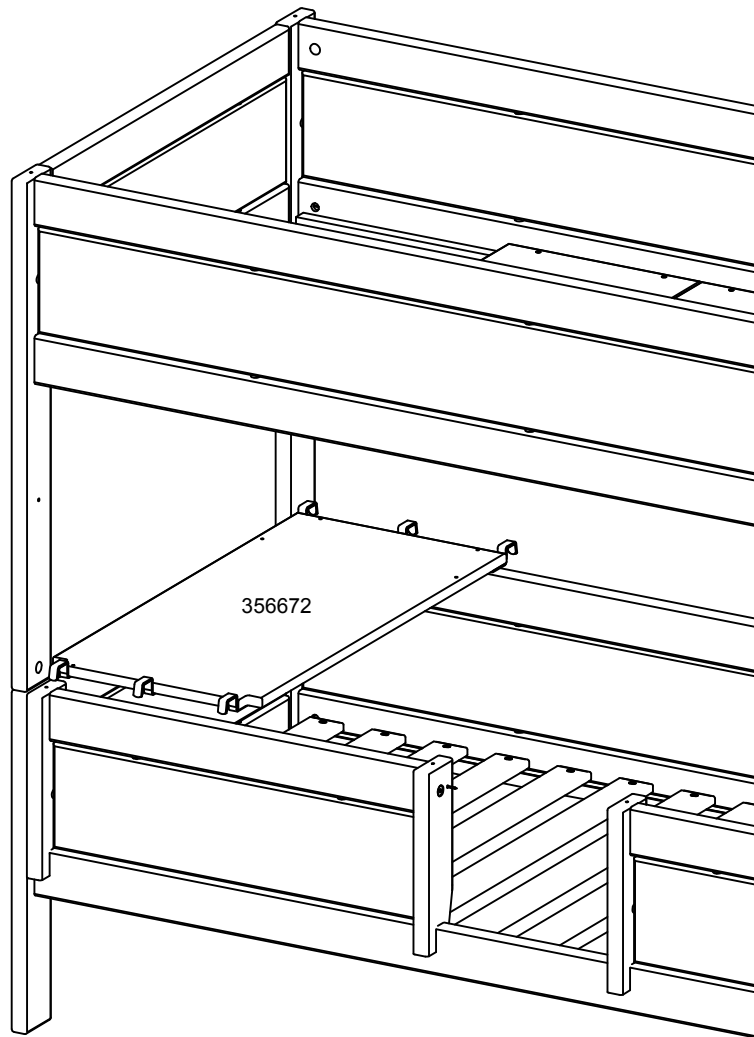

7

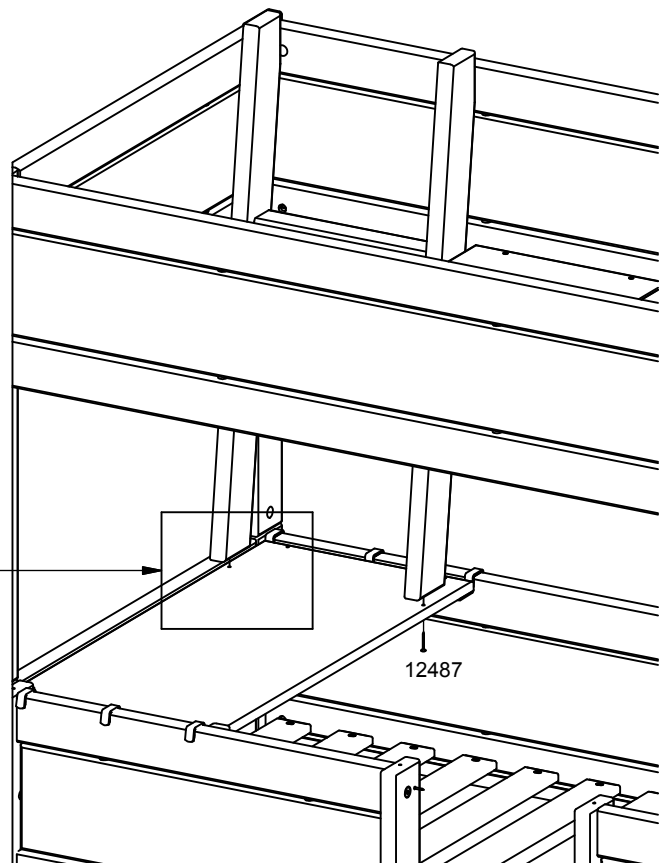
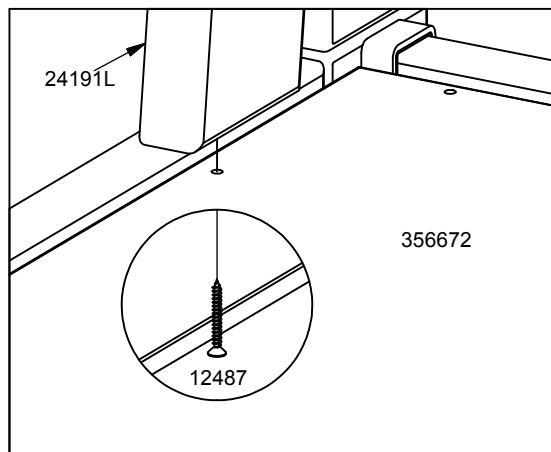

8

12487 x 4  
ø4 x 35mm

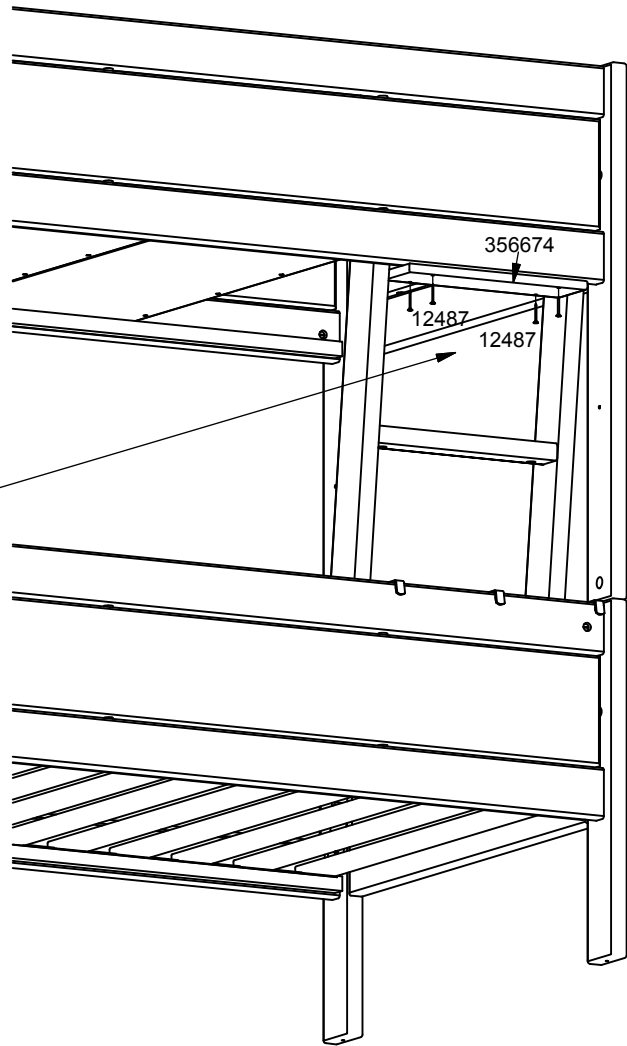
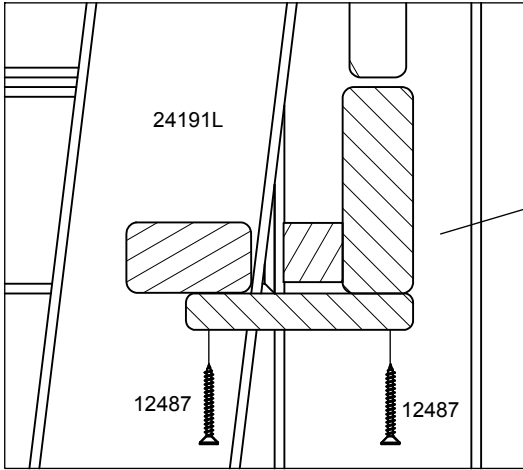

9

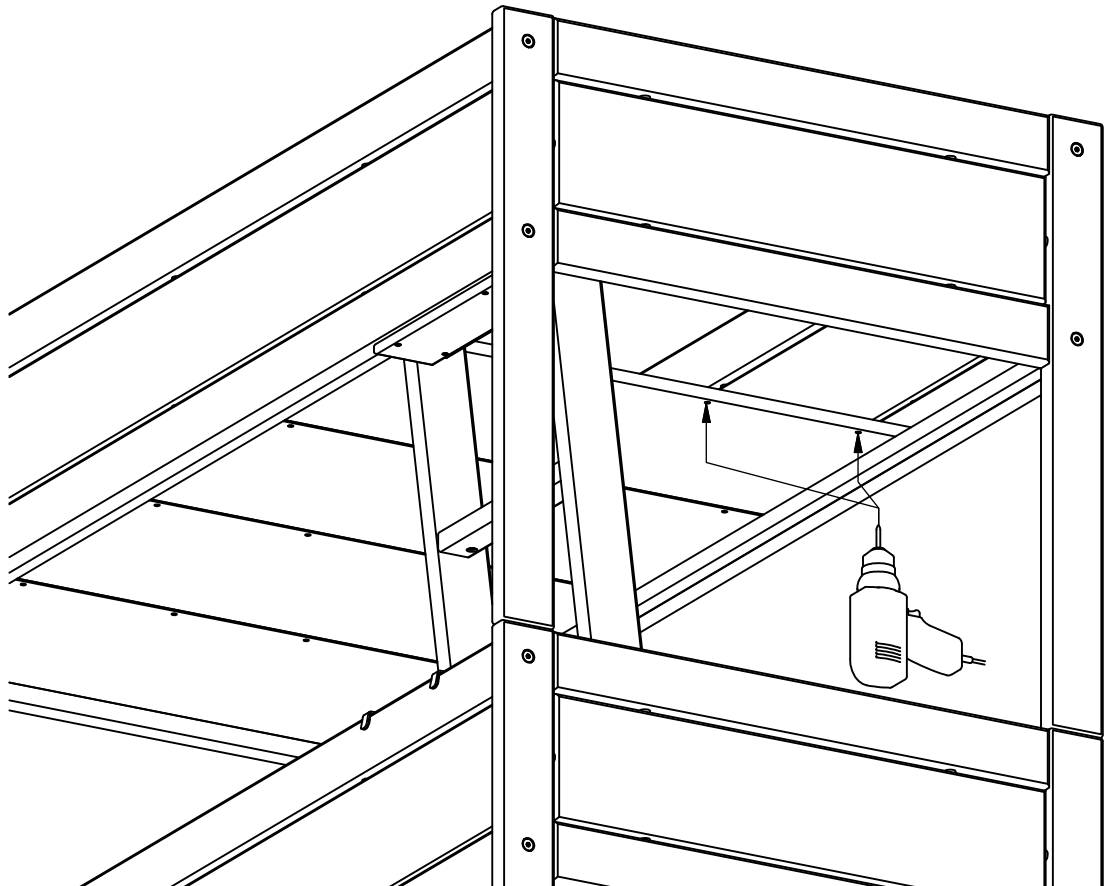

10



12301 x 1  
28 x 20mm



12349 x 1  
ø4,2 x 10,5mm



12025 x 2  
M6, ø10 x 14mm



12030 x 2  
M6 x 65mm

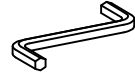

12323 x 1  
4mm

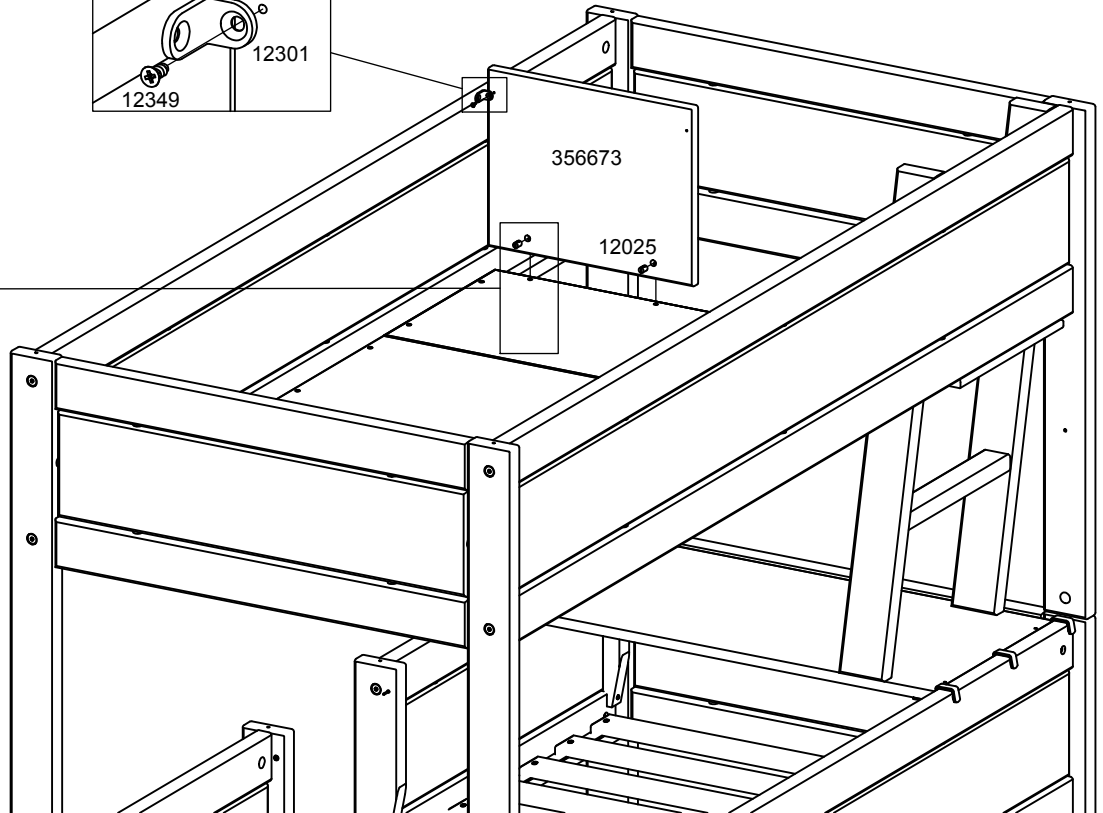
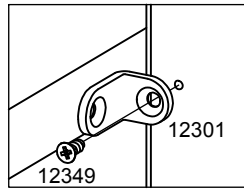
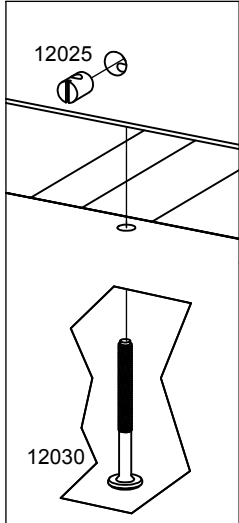

11



12461 x 1  
ø4 x 20mm

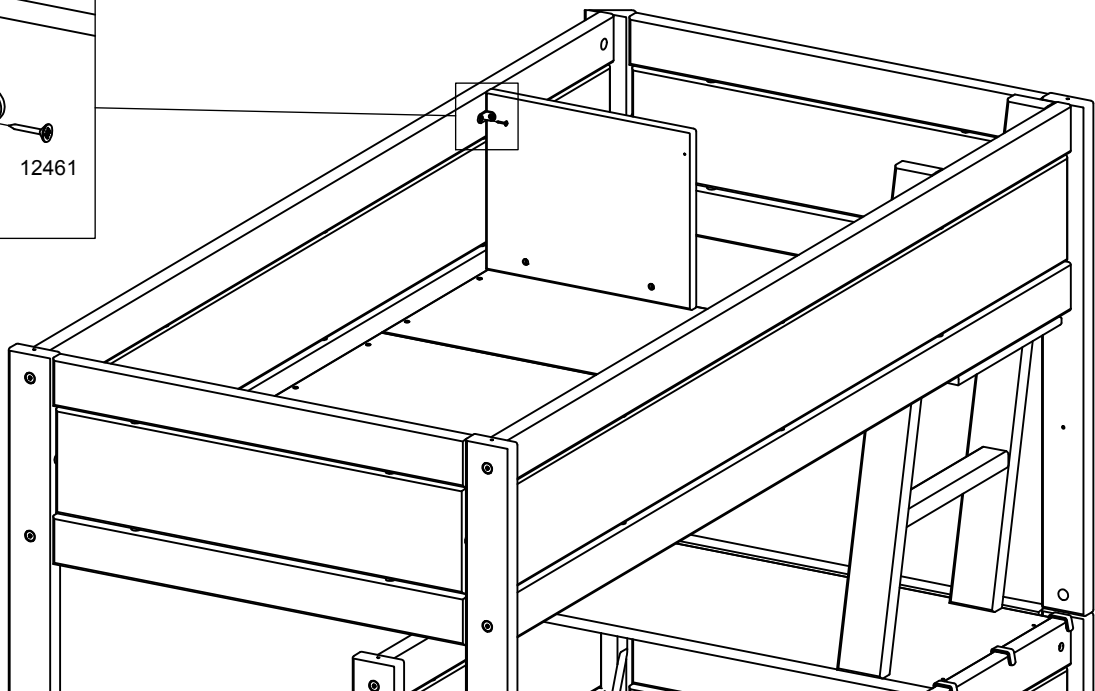
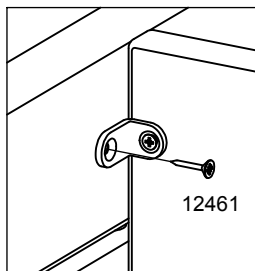



12



12487 x 4  
ø4 x 35mm

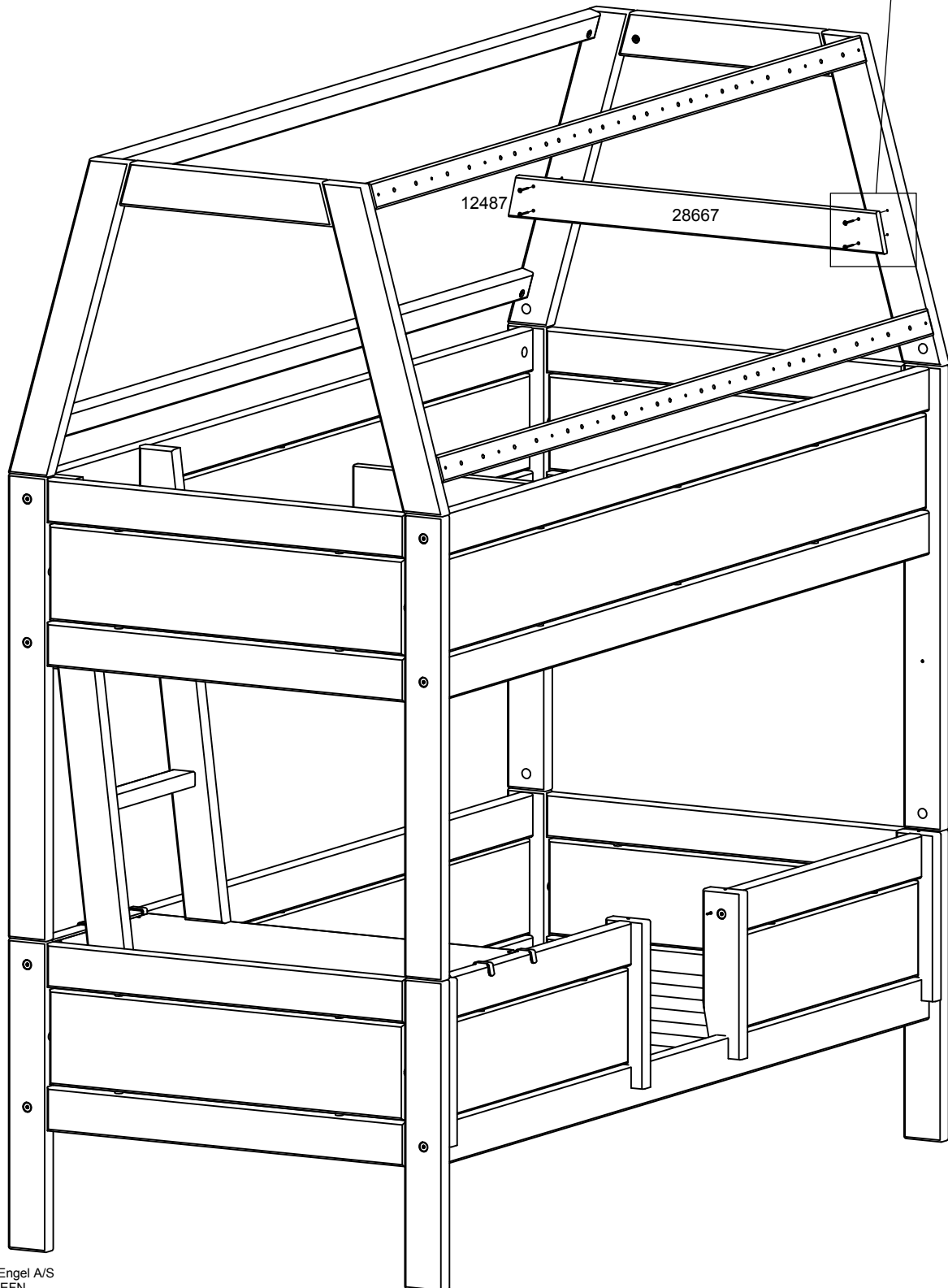
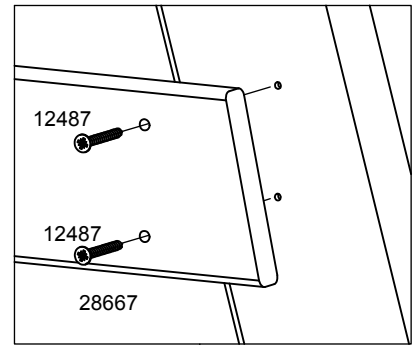



**LIFETIME**  
KIDSROOMS

Samlevejledning  
Assembly Instructions  
Bauanleitung  
Montage handleiding  
Notice de montage  
Istruzioni di montaggio

**Art: 6367**

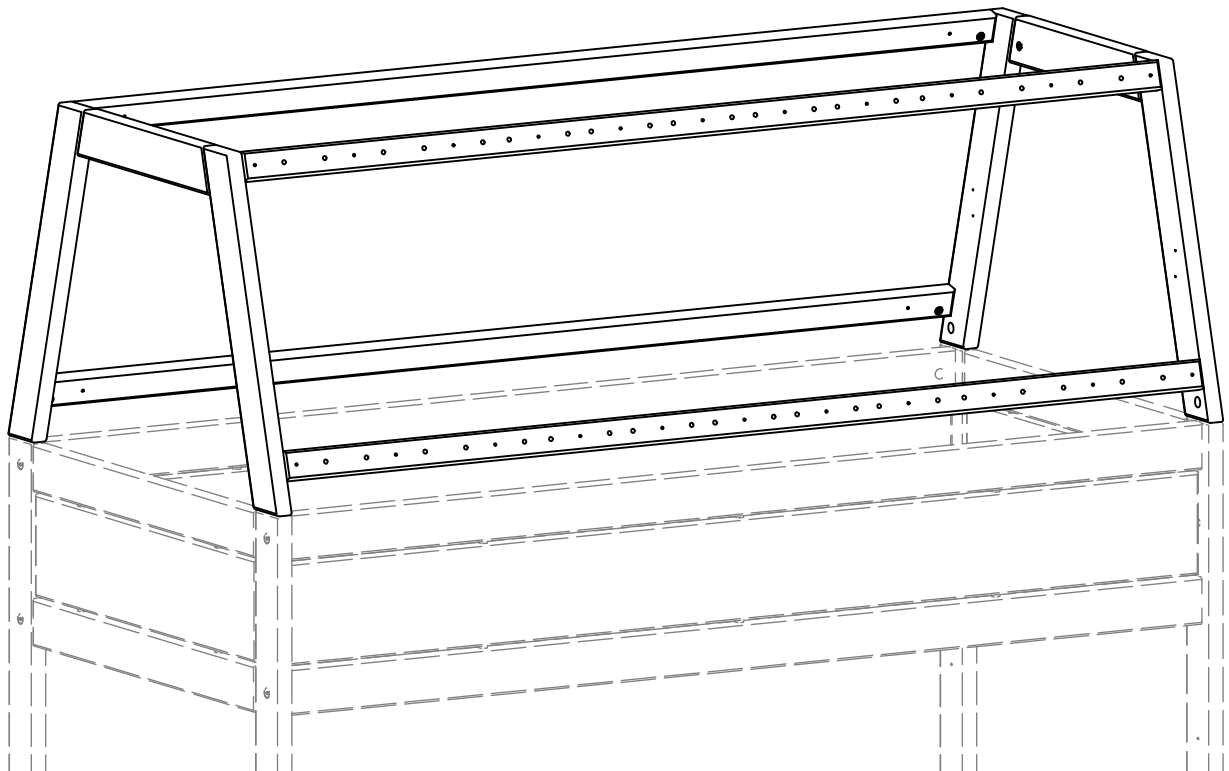

**VIGTIGT !****IMPORTANT !****WICHTIG !****BELANGRIJK !**

- DK Før du starter. Læs venligst denne instruktion grundigt igennem og opbevar denne til evt senere brug. Sørg for at plastikposer ikke kommer i små børns hænder og vær sikker på, at der ikke er små børn i nærheden, under montagen, da der er små dele i pakken.
- UK Before you start. Please read instructions carefully and retain for future reference. Please dispose carefully of packing materials. Keep plastic bags away from young children. Ensure young children are kept clear during assembly as this pack contains small parts.
- D Bevor Sie anfangen lesen Sie bitte die Bauanleitung sorgfältig durch und bewahren Sie diese Anleitung auf. Versichern Sie sich, dass keine kleinen Kinder in der Nähe sind während Sie aufbauen weil die Verpackung kleinste Teile beinhaltet. Plastic Verpackungsteile daher bitte gleich wegwerfen.
- NL Voordat u begint, lees a.u.b. de montage-instructie aandachtig door en bewaar deze zorgvuldig. Plastic verpakkingsmateriaal weghouden bij jonge kinderen. Wees er zeker van dat tijdens het monteren van het bed de kinderen op veilige afstand zijn omdat de verpakking kleine onderdelen bevat.
- F Avant de commencer. Veuillez lire cette notice soigneusement et pensez à la garder pour une utilisation ultérieure. Veuillez à ne pas laisser les sachets plastiques accessibles aux enfants, et à éloigner les enfants pendant le montage car présence de petits objets dans les colis.
- I Prima di iniziare. Si prega di leggere attentamente le istruzioni e di conservarle per un uso successivo. Tenere lontano dalla portata dei bambini il pacchetto perché contiene piccole parti di assemblaggio e fare attenzione a non lasciarle in giro.

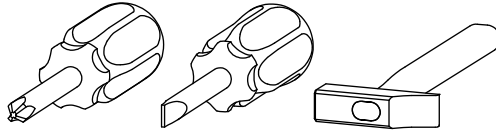
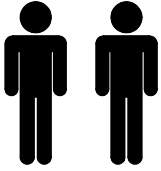

Art: 6367

Colli: 1

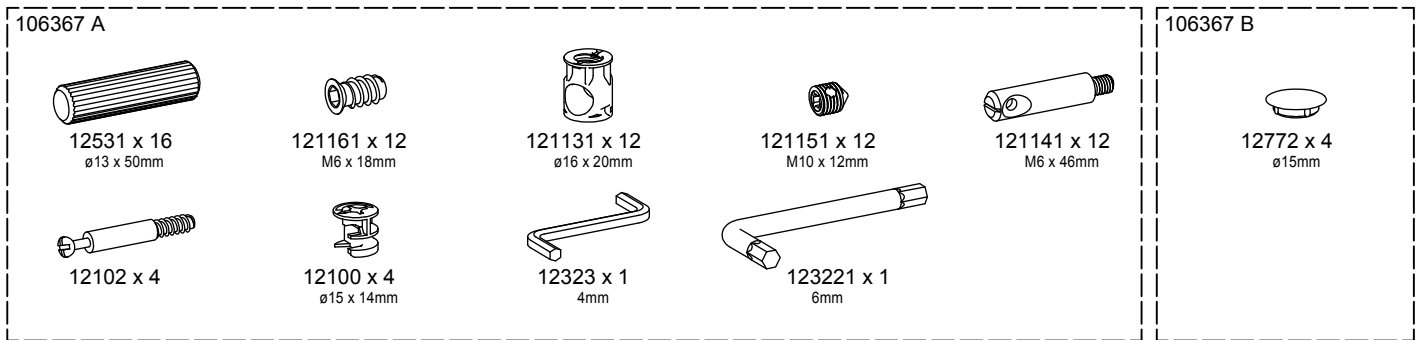

6367

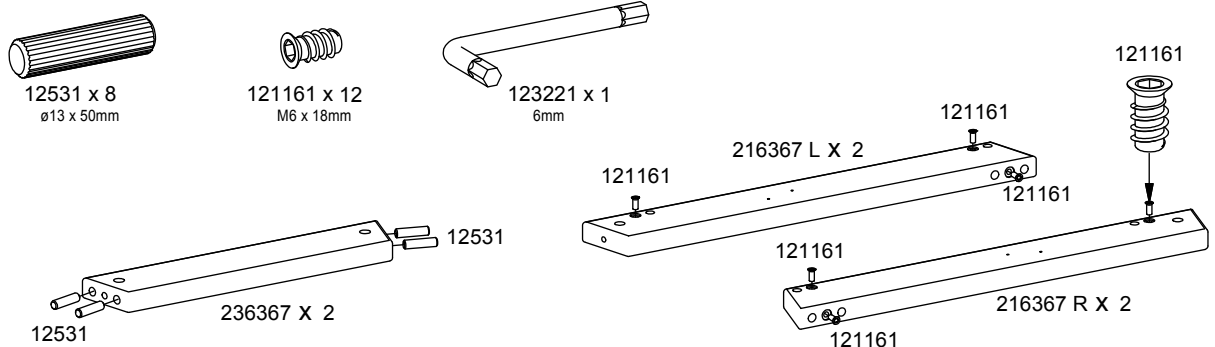
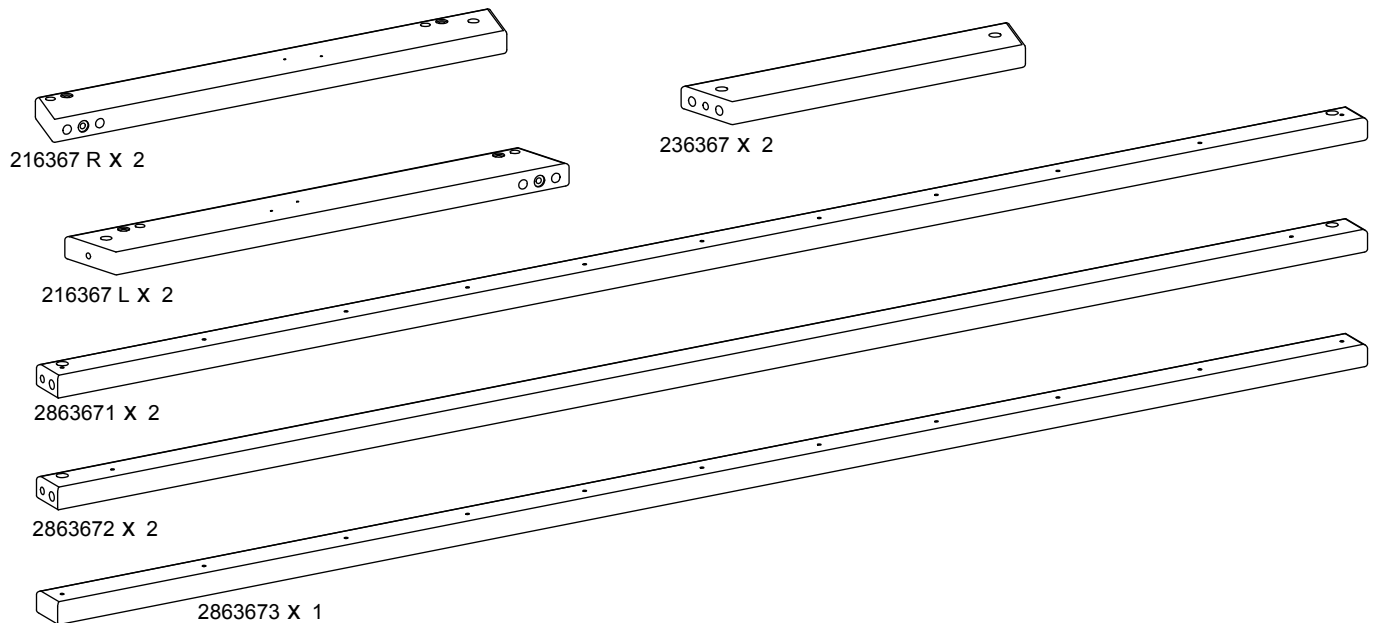

2

121141 x 12  
M6 x 46mm

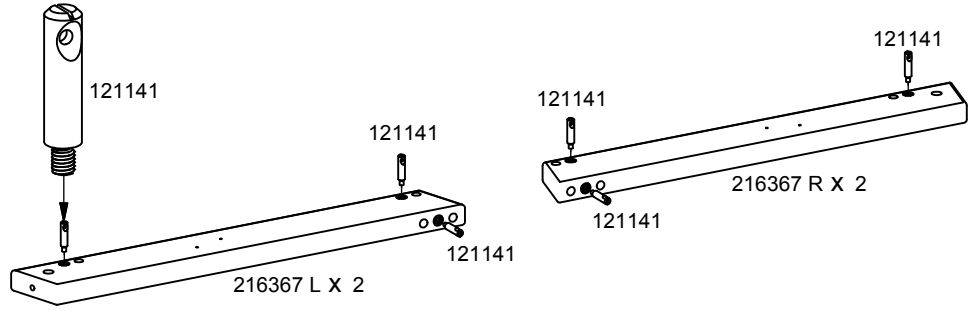

3

121131 x 4  
ø16 x 20mm

121151 x 4  
M10 x 12mm

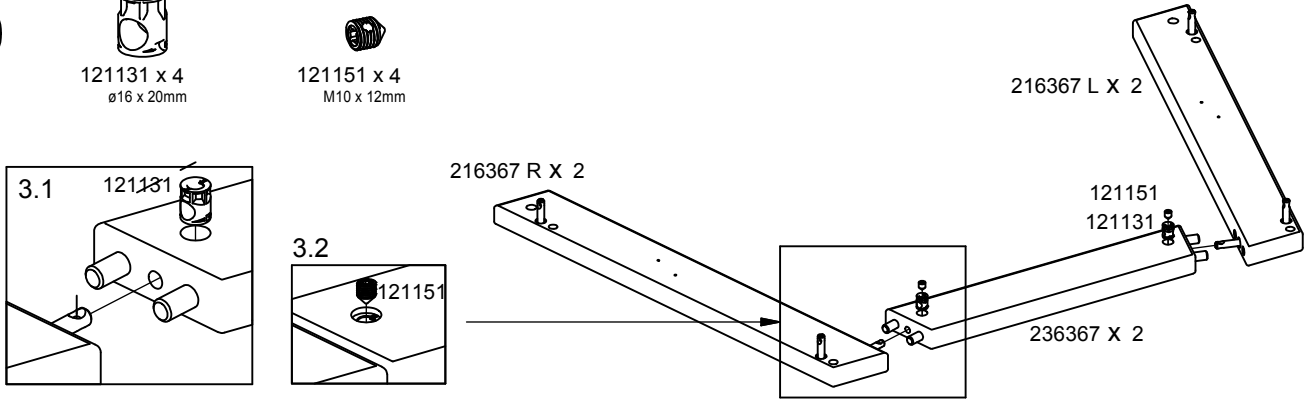

4

12531 x 8  
ø13 x 50mm

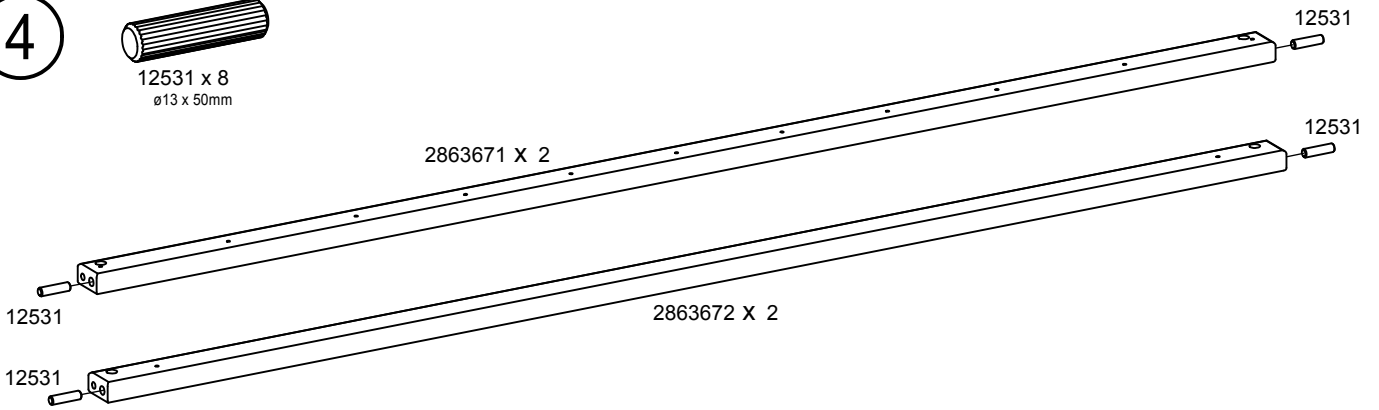

5

121131 x 8  
ø16 x 20mm

121151 x 8  
M10 x 12mm

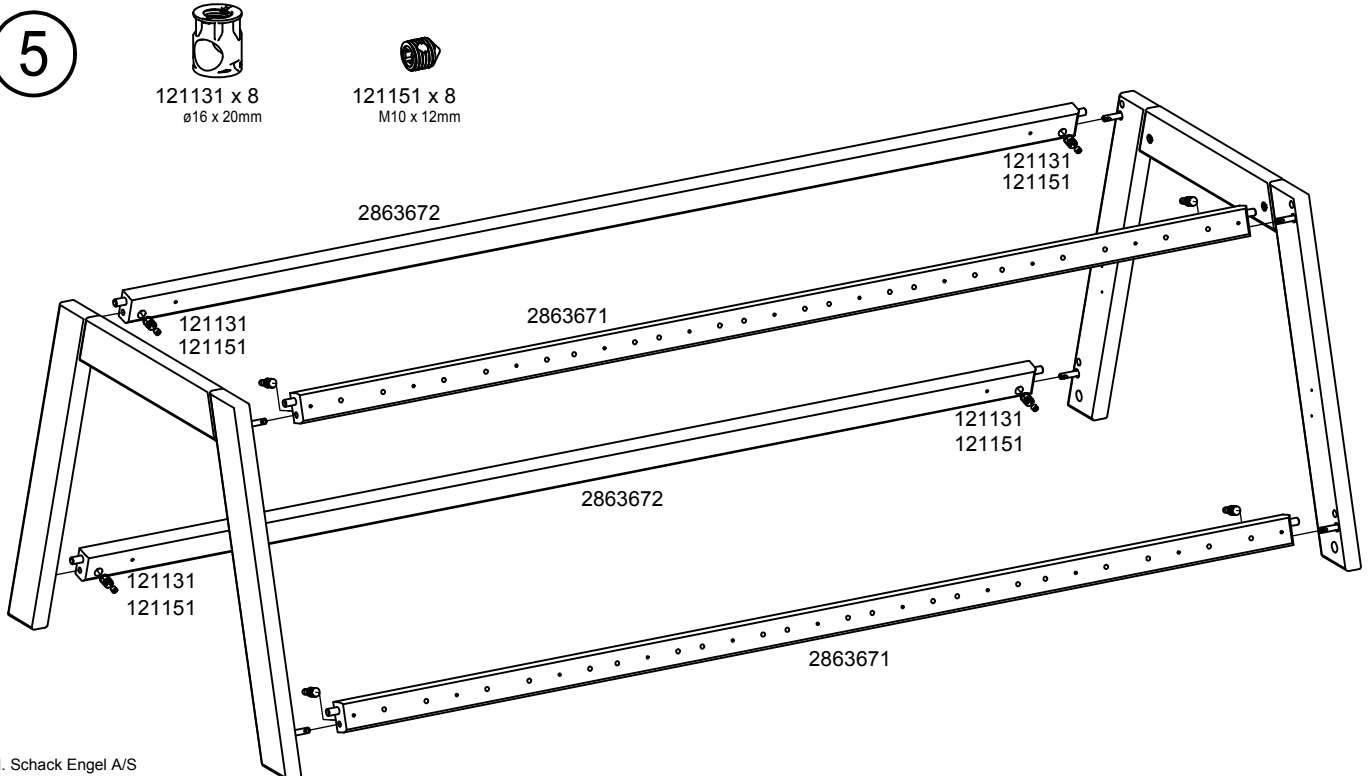

6

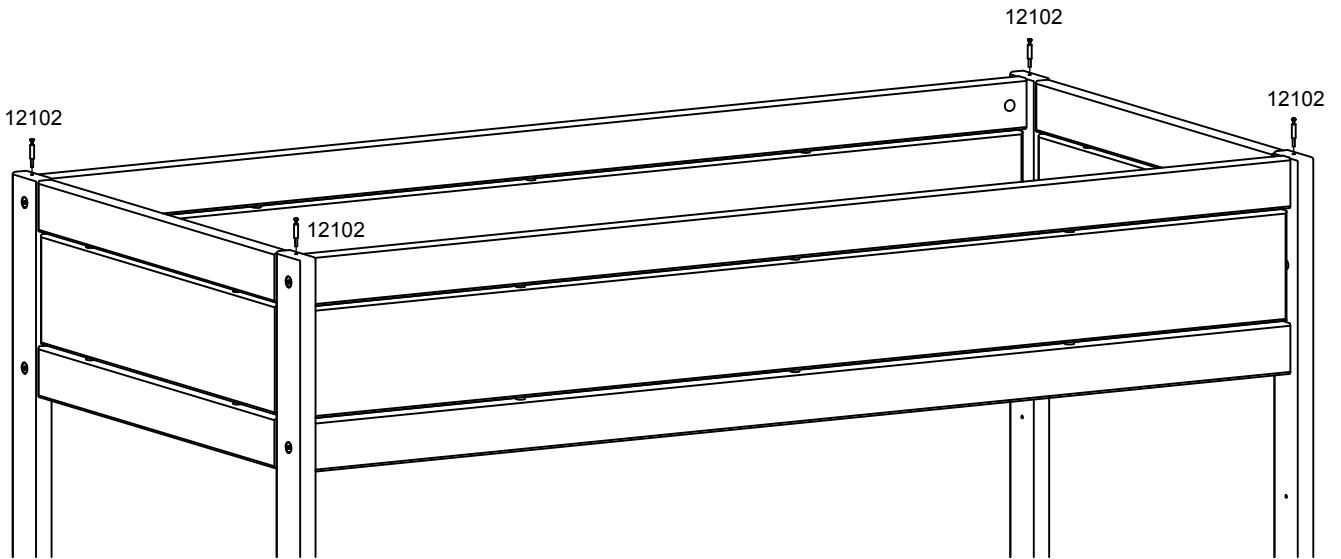
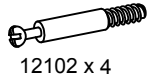

7



12100 x 4  
ø15 x 14mm



12772 x 4  
ø15mm

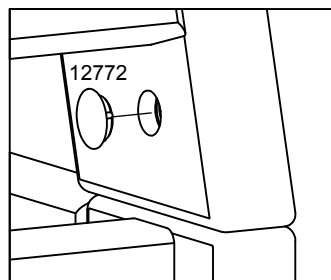
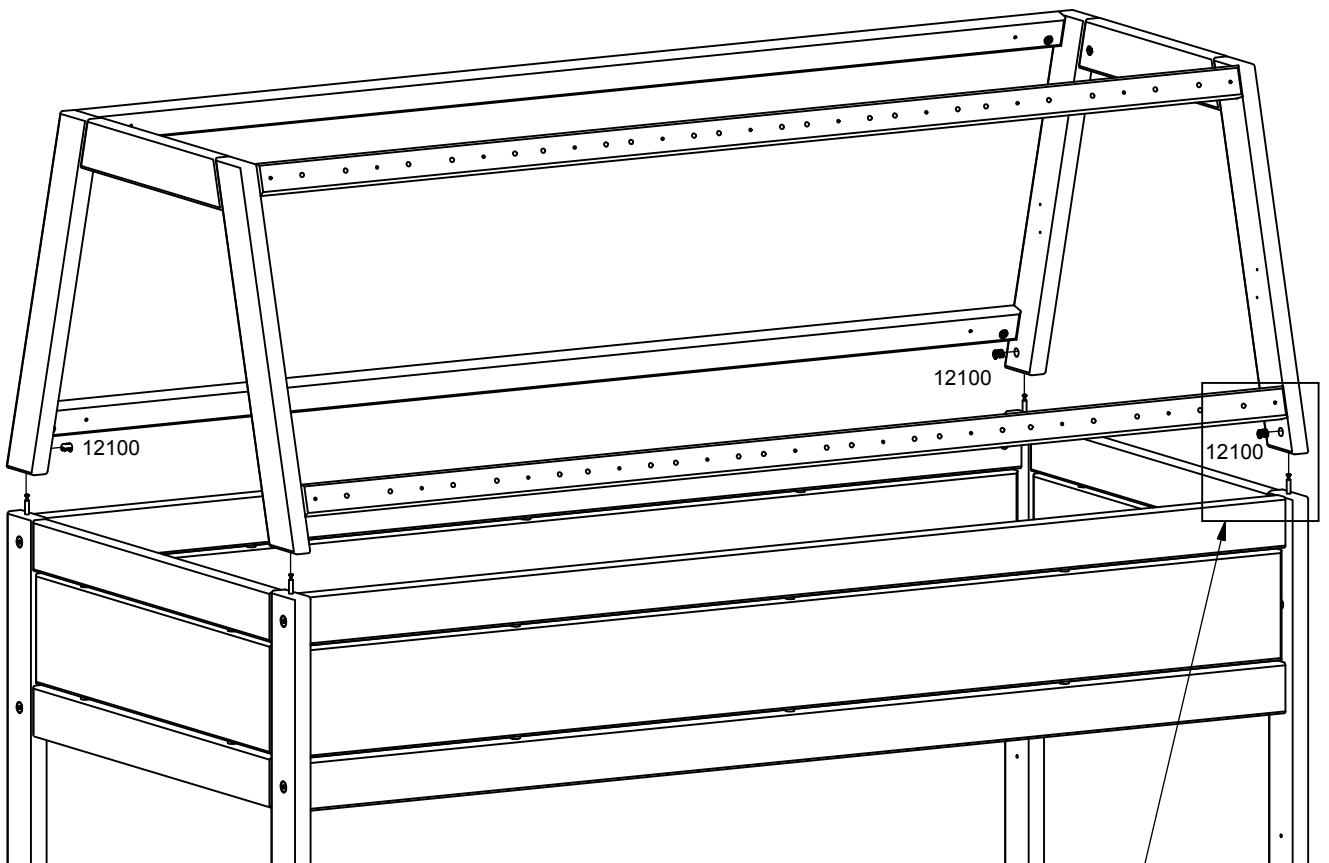



**LIFETIME**  
KIDSROOMS

Samlevejledning  
Assembly Instructions  
Bauanleitung  
Montage handleiding  
Notice de montage  
Istruzioni di montaggio

**Art: 6368**

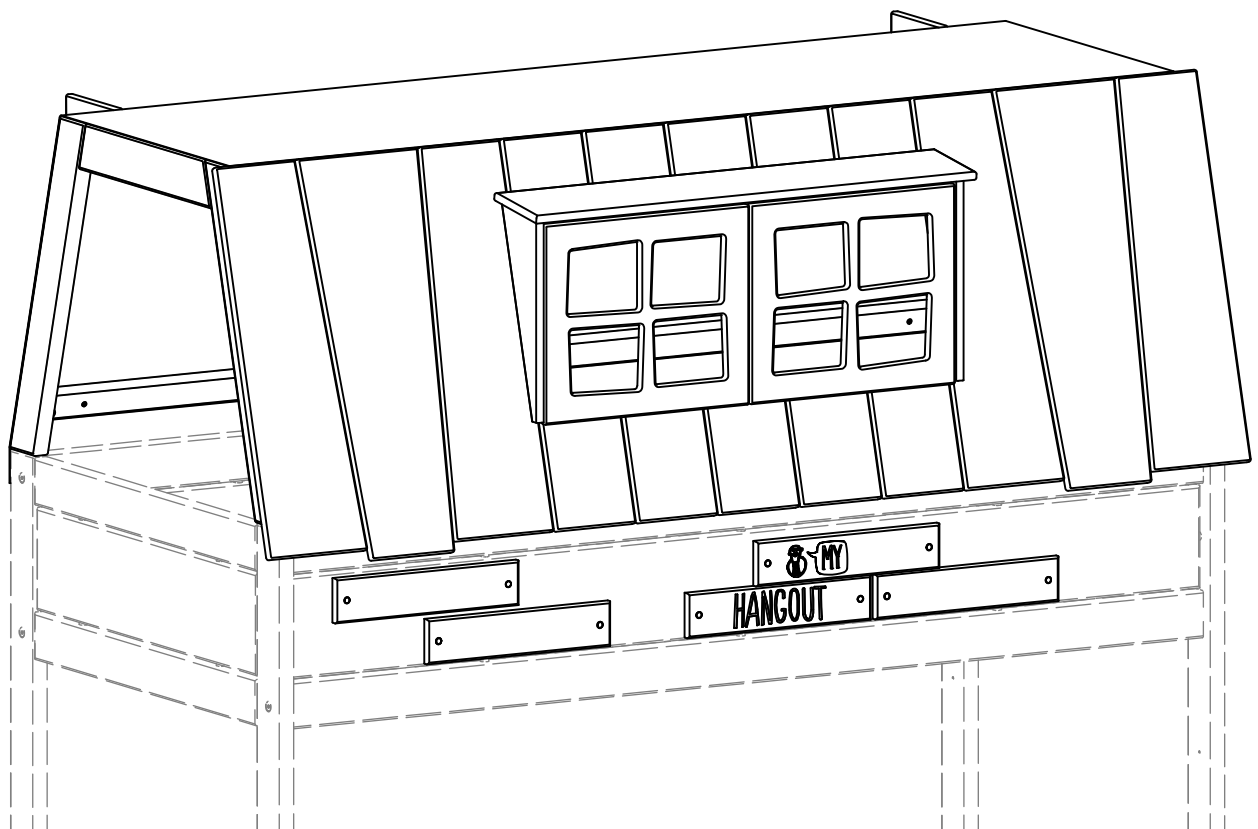

# VIGTIGT! IMPORTANT! WICHTIG! BELANGRIJK! IMPORTANT! IMPORTANTE!

- DK** Før du starter. Læs venligst denne instruktion grundigt igennem og opbevar denne til evt senere brug. Sørg for at plastikposer ikke kommer i små børns hænder og vær sikker på, at der ikke er små børn i nærheden, under montagen, da der er små dele i pakken.
- UK** Before you start. Please read instructions carefully and retain for future reference. Please dispose carefully of packing materials. Keep plastic bags away from young children. Ensure young children are kept clear during assembly as this pack contains small parts.
- D** Bevor Sie anfangen lesen Sie bitte die Bauanleitung sorgfältig durch und bewahren Sie diese Anleitung auf. Versichern Sie sich, dass keine kleinen Kinder in der Nähe sind während Sie aufbauen weil die Verpackung kleinste Teile beinhaltet. Plastic Verpackungsteile daher bitte gleich wegwerfen.
- NL** Voordat u begint, lees a.u.b. de montage-instructie aandachtig door en bewaar deze zorgvuldig. Plastic verpakkingsmateriaal weghouden bij jonge kinderen. Wees er zeker van dat tijdens het monteren van het bed de kinderen op veilige afstand zijn omdat de verpakking kleine onderdelen bevat.
- F** Avant de commencer. Veuillez lire cette notice soigneusement et pensez à la garder pour une utilisation ultérieure. Veillez à ne pas laisser les sachets plastiques accessibles aux enfants, et à éloigner les enfants pendant le montage car présence de petits objets dans les colis.
- I** Prima di iniziare. Si prega di leggere attentamente le istruzioni e di conservarle per un uso successivo. Tenere lontano dalla portata dei bambini il pacchetto perché contiene piccole parti di assemblaggio e fare attenzione a non lasciarle in giro.

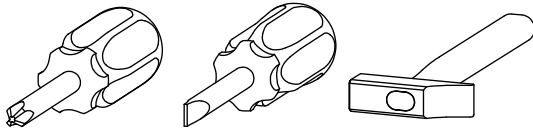
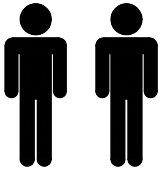

Art: 6368

Colli: 1

406368

106368A

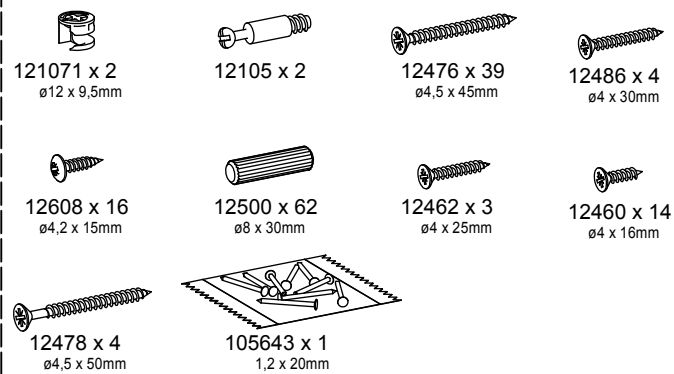

106368B

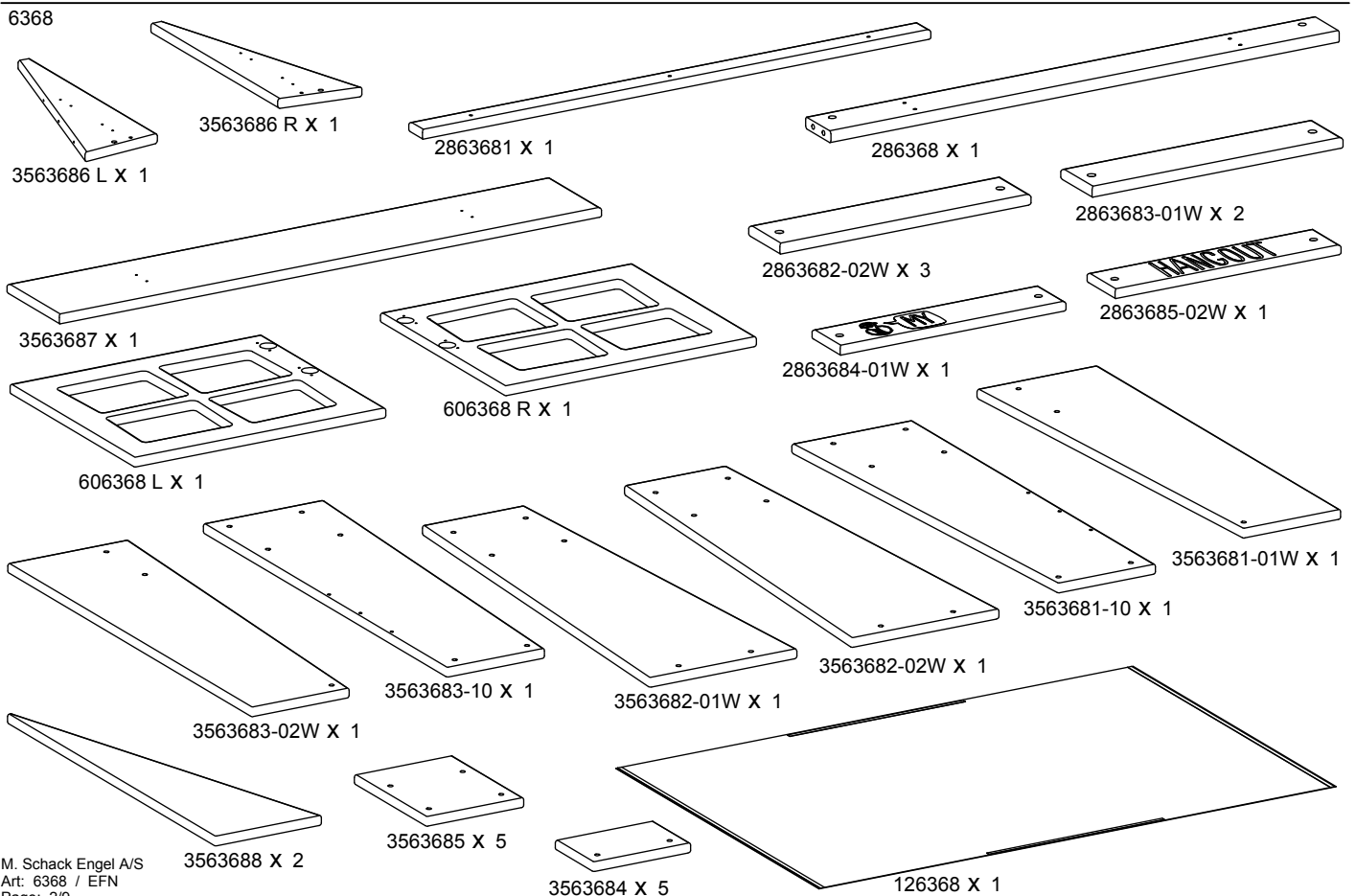
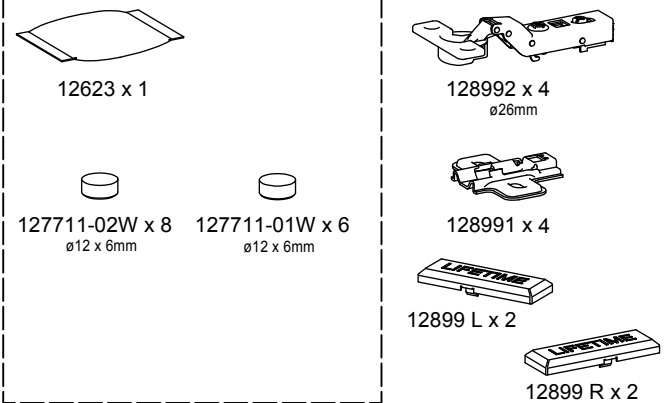

1

12500 x 60  
ø8 x 30mm

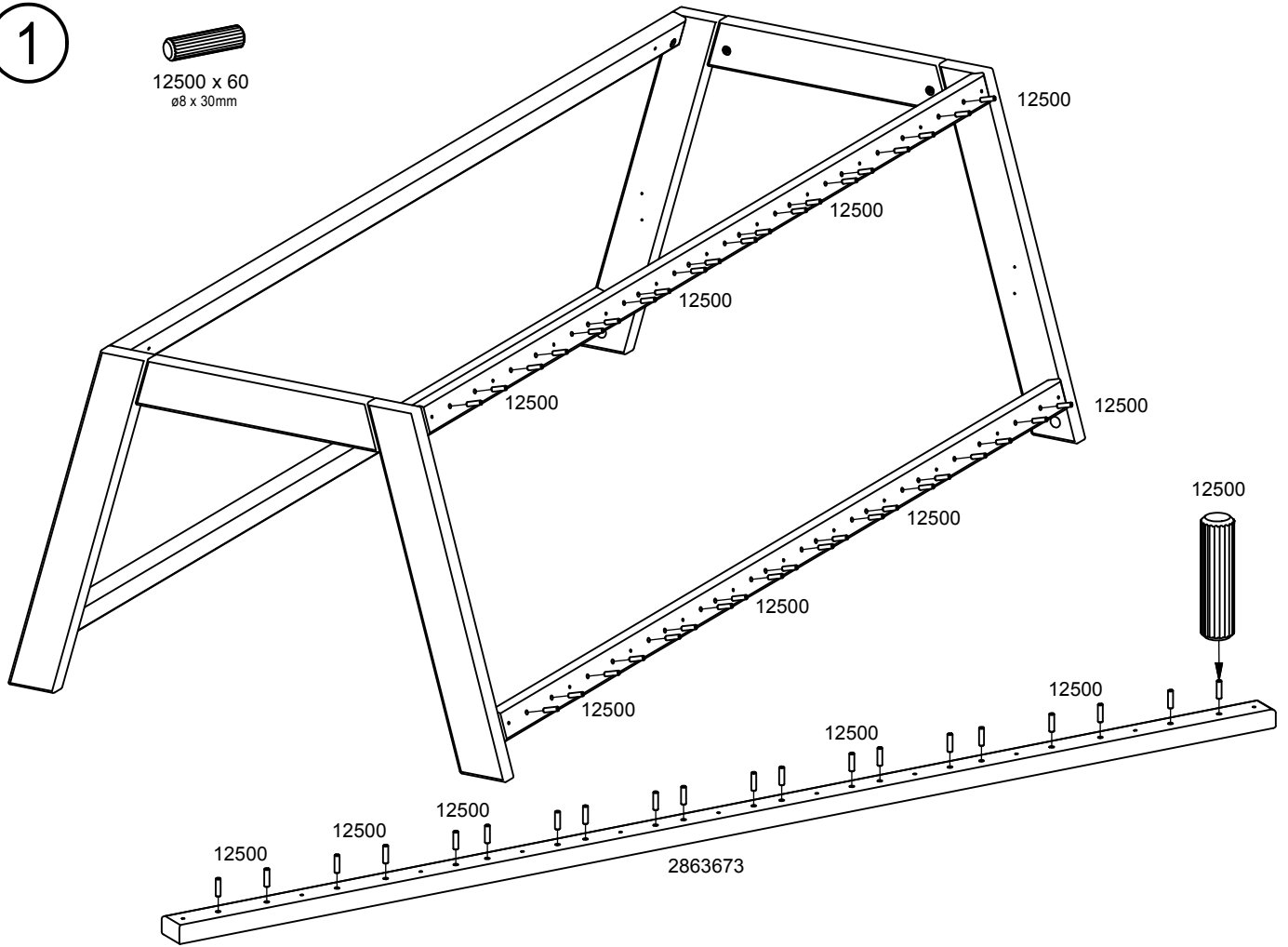

2

12476 x 22  
ø4.5 x 45mm

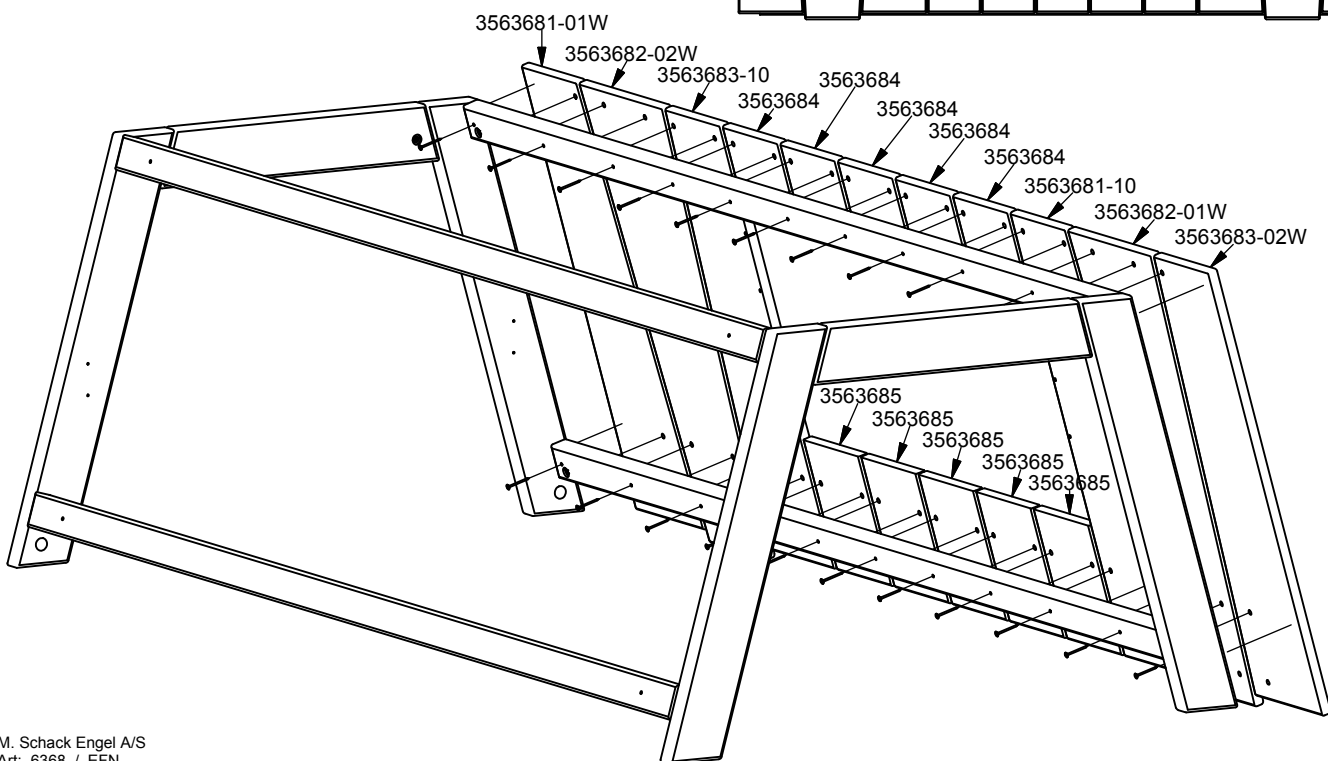
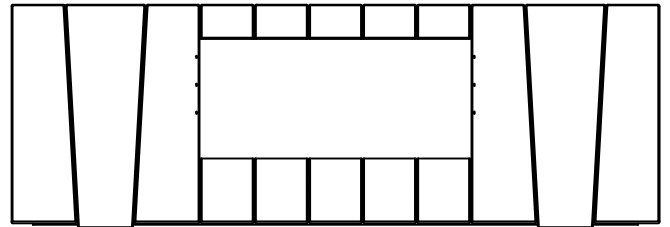



3

12476 x 11  
ø4,5 x 45mm

12462 x 3  
ø4 x 25mm

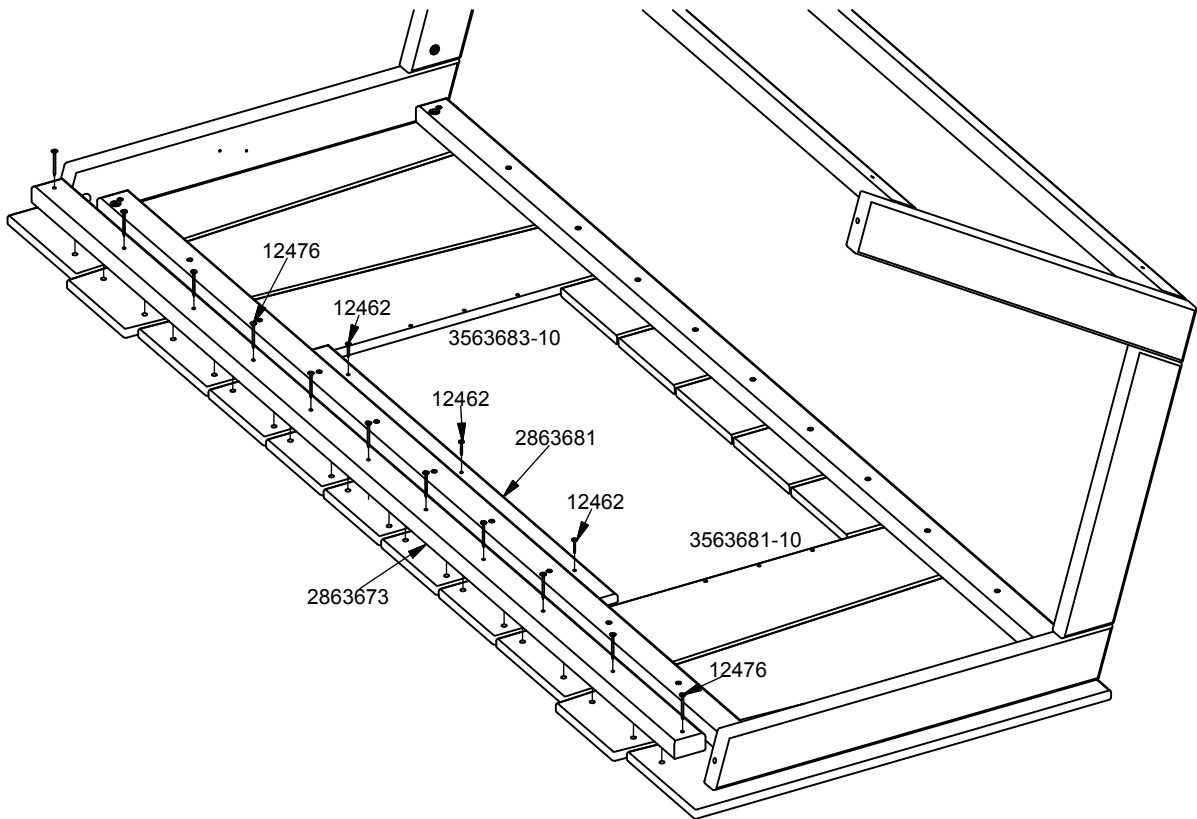

4

12500 x 2  
ø8 x 30mm

12105 x 2

128991 x 4

12608 x 8  
ø4,2 x 15mm

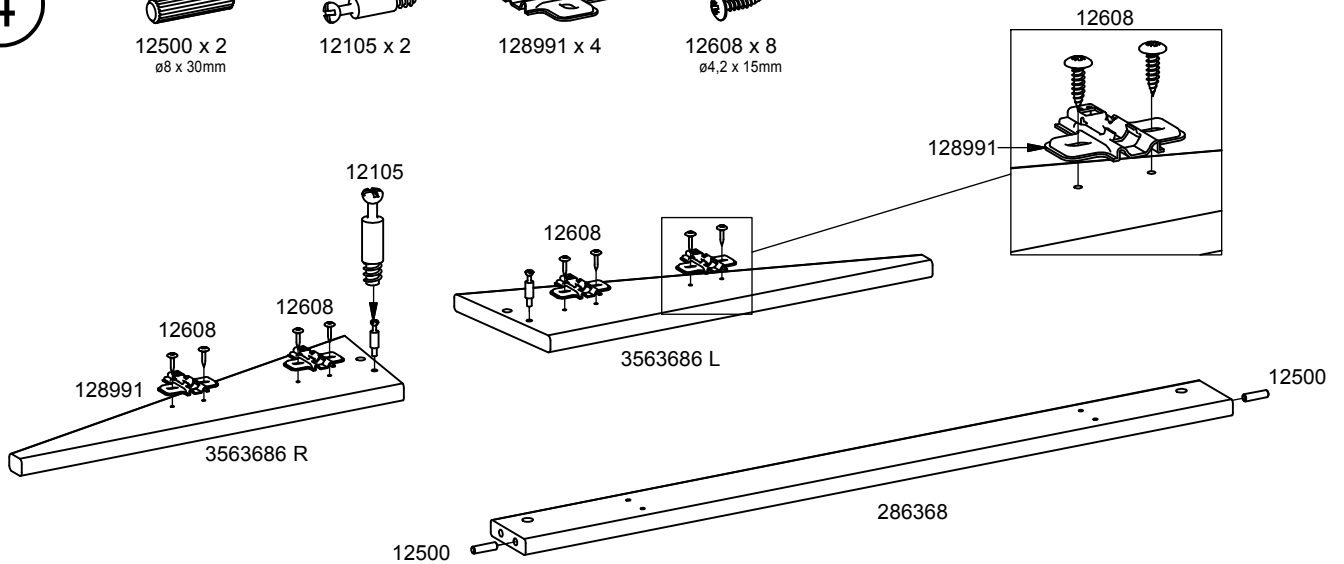

5

121071 x 2  
ø12 x 9,5mm

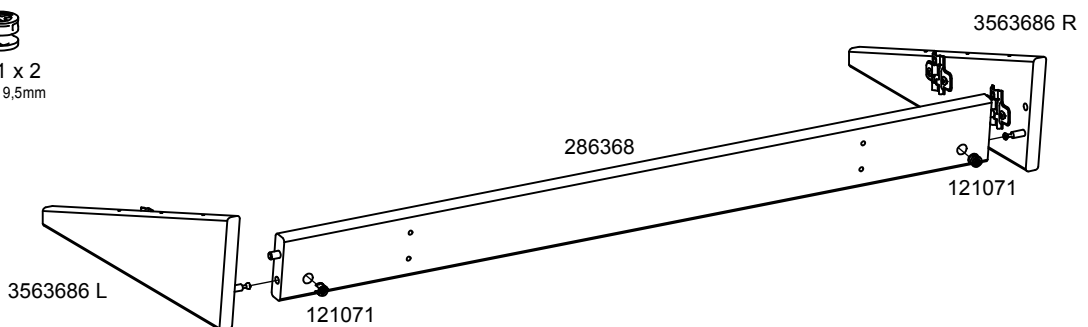

6

12486 x 4  
ø4 x 30mm

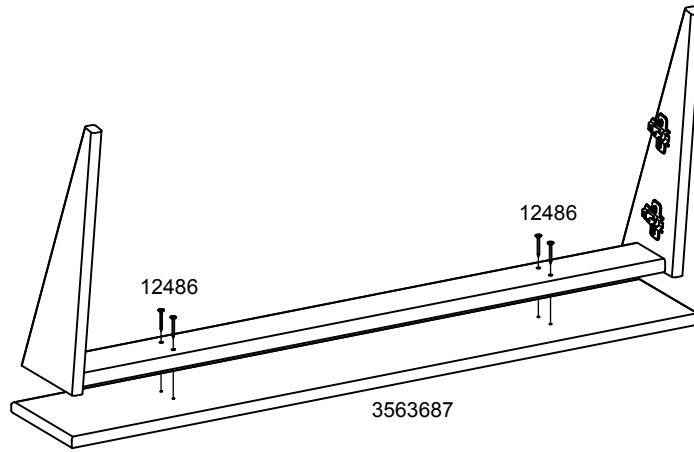

7

12476 x 6  
ø4,5 x 45mm

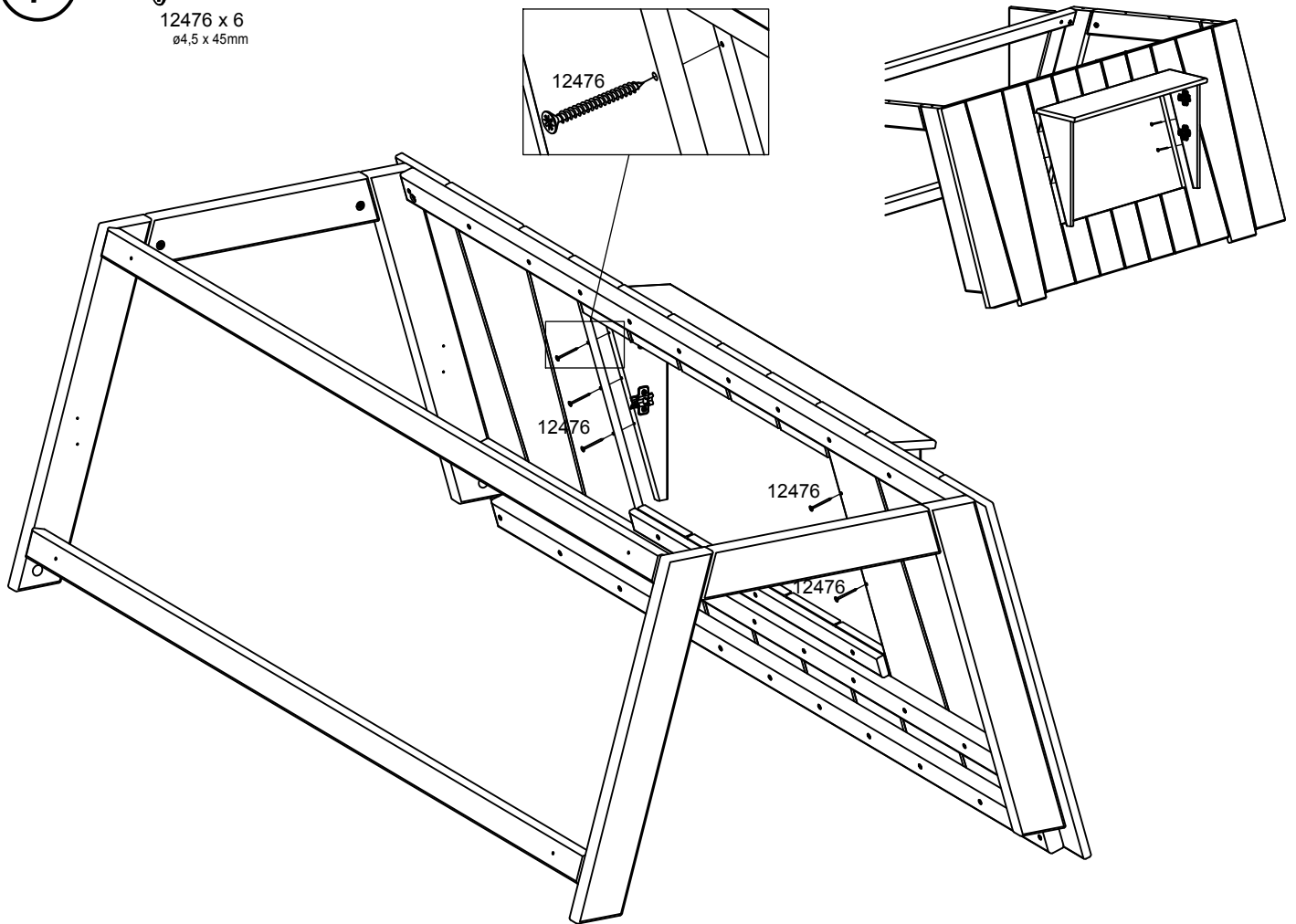

8

128992 x 4  
ø26mm

12608 x 8  
ø4,2 x 15mm

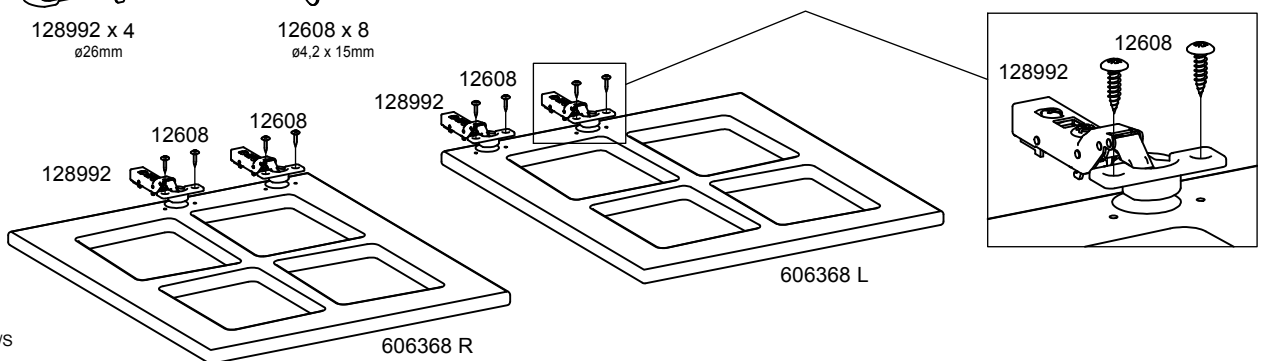

9

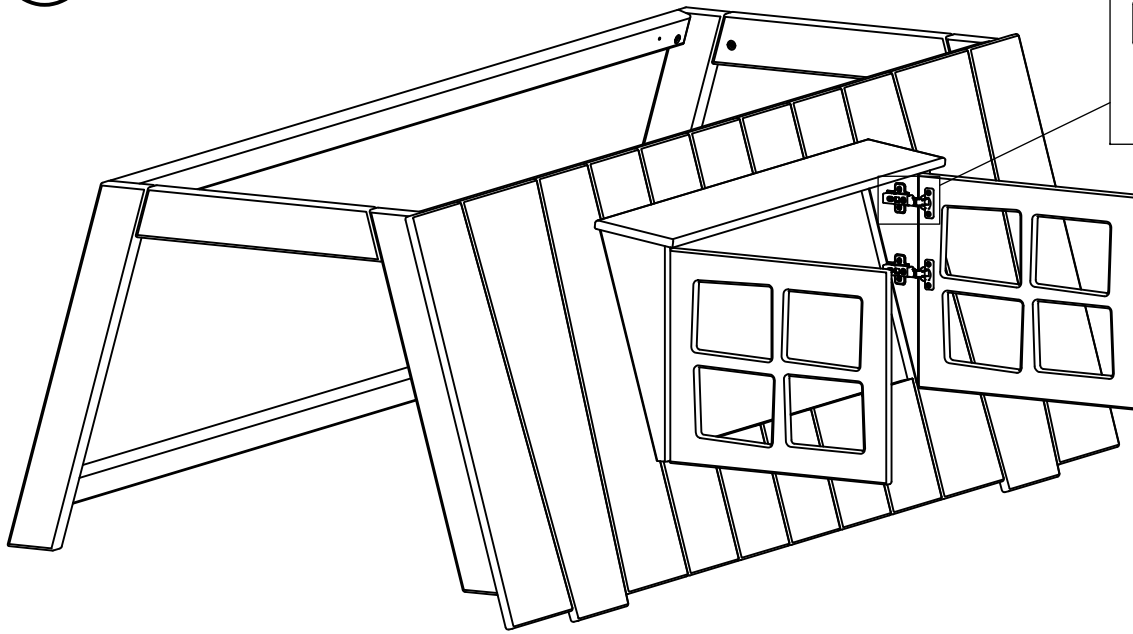

10



105653 x 1  
1,2 x 20mm

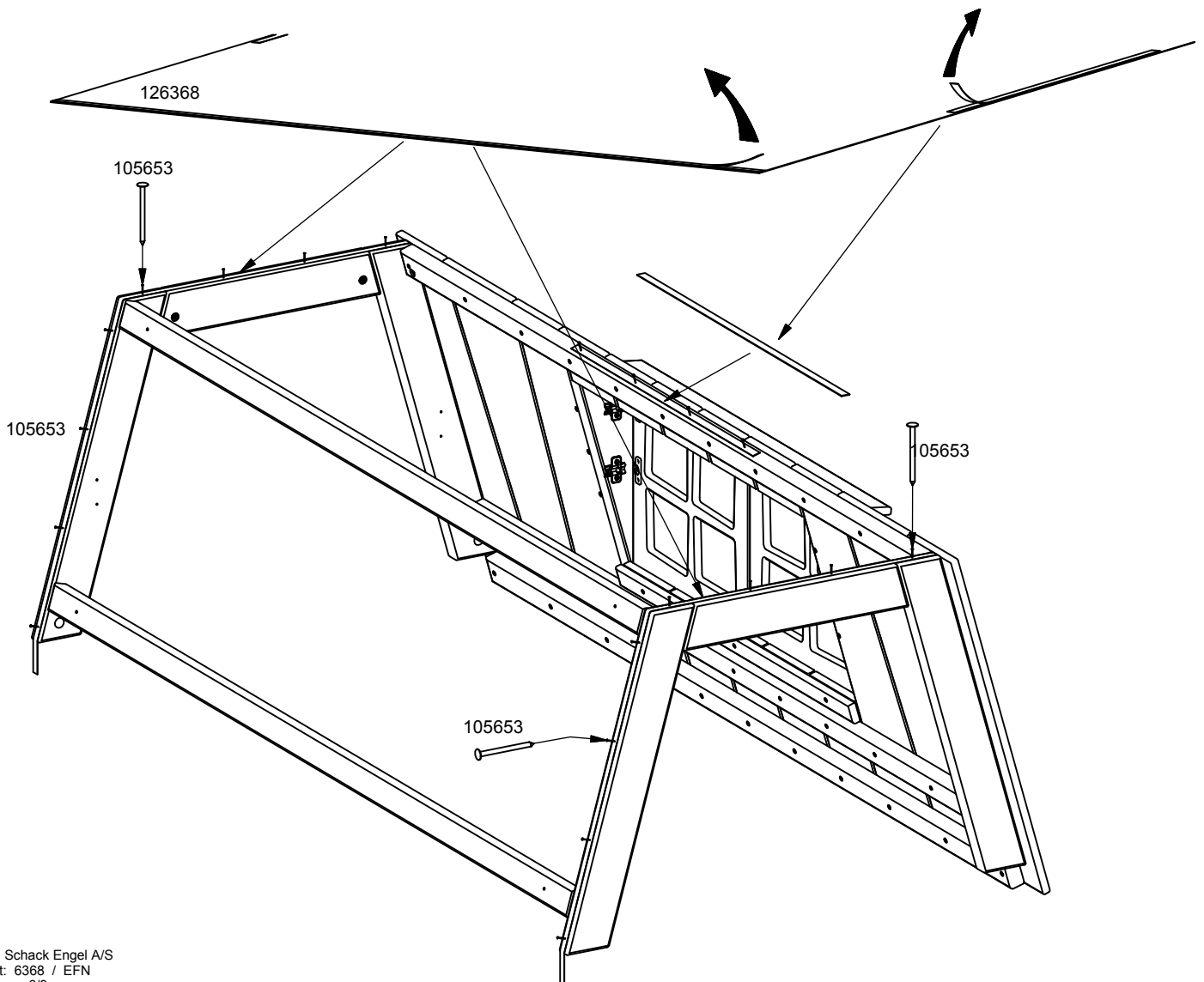

11

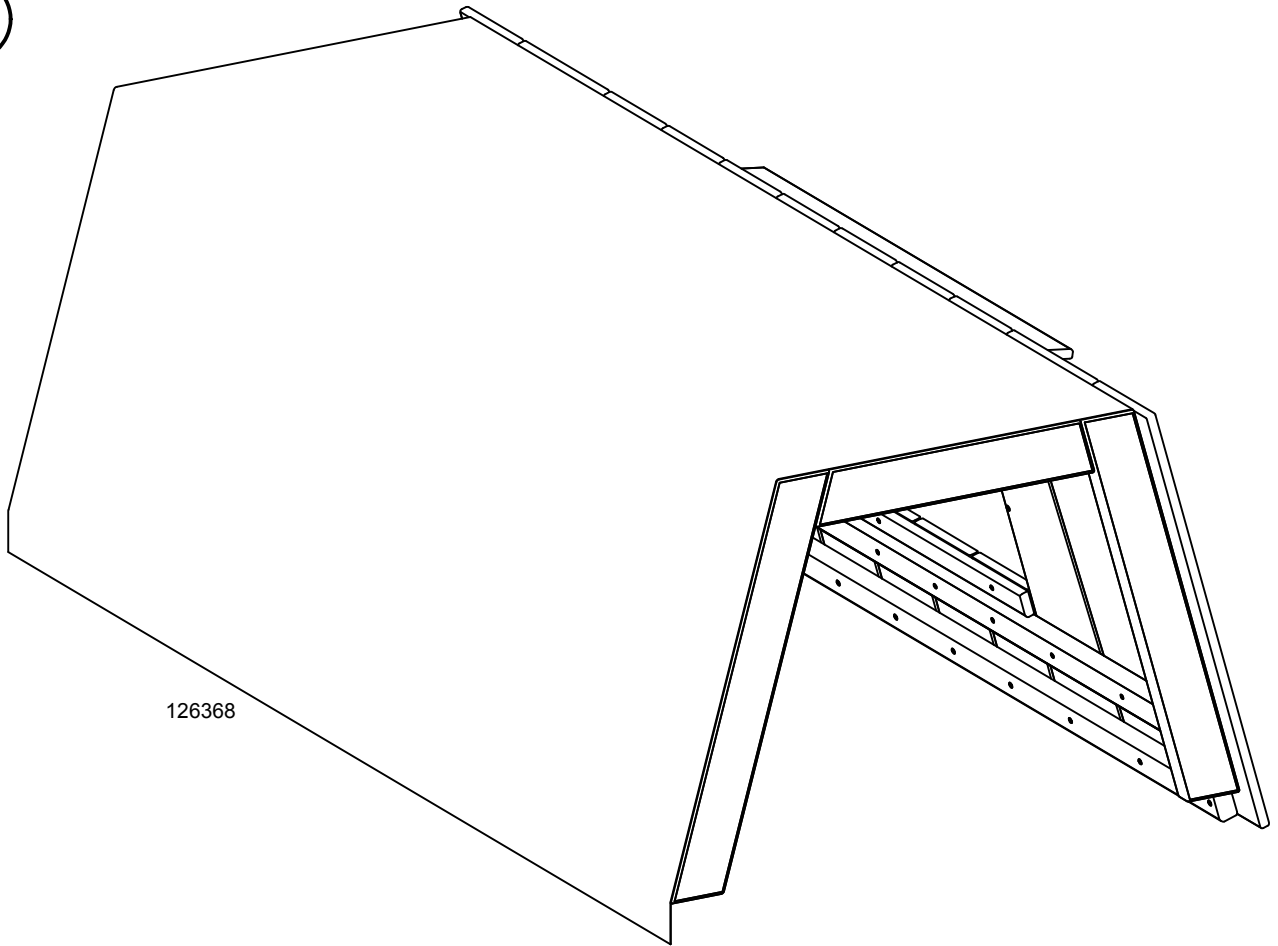

12

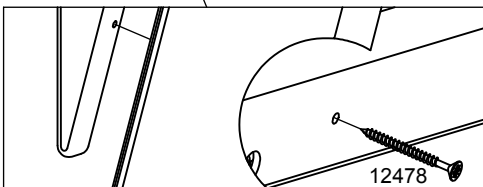
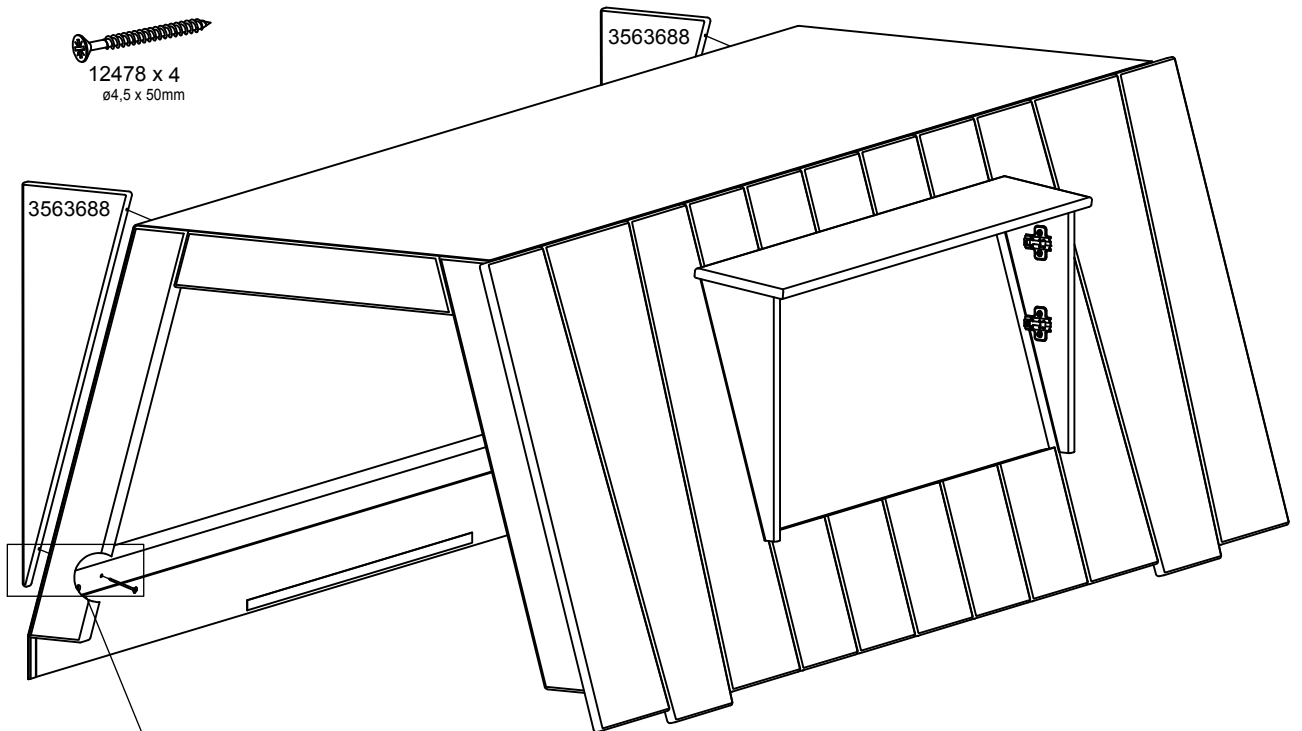

13

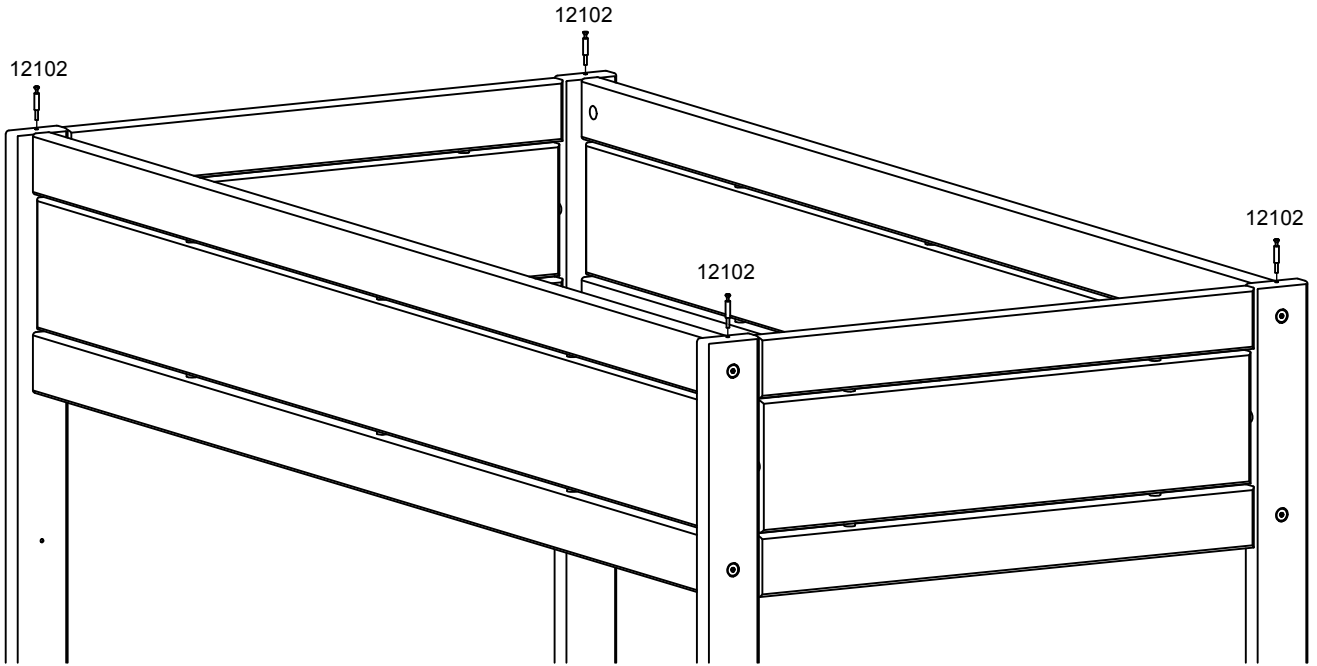
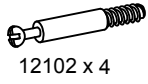

14

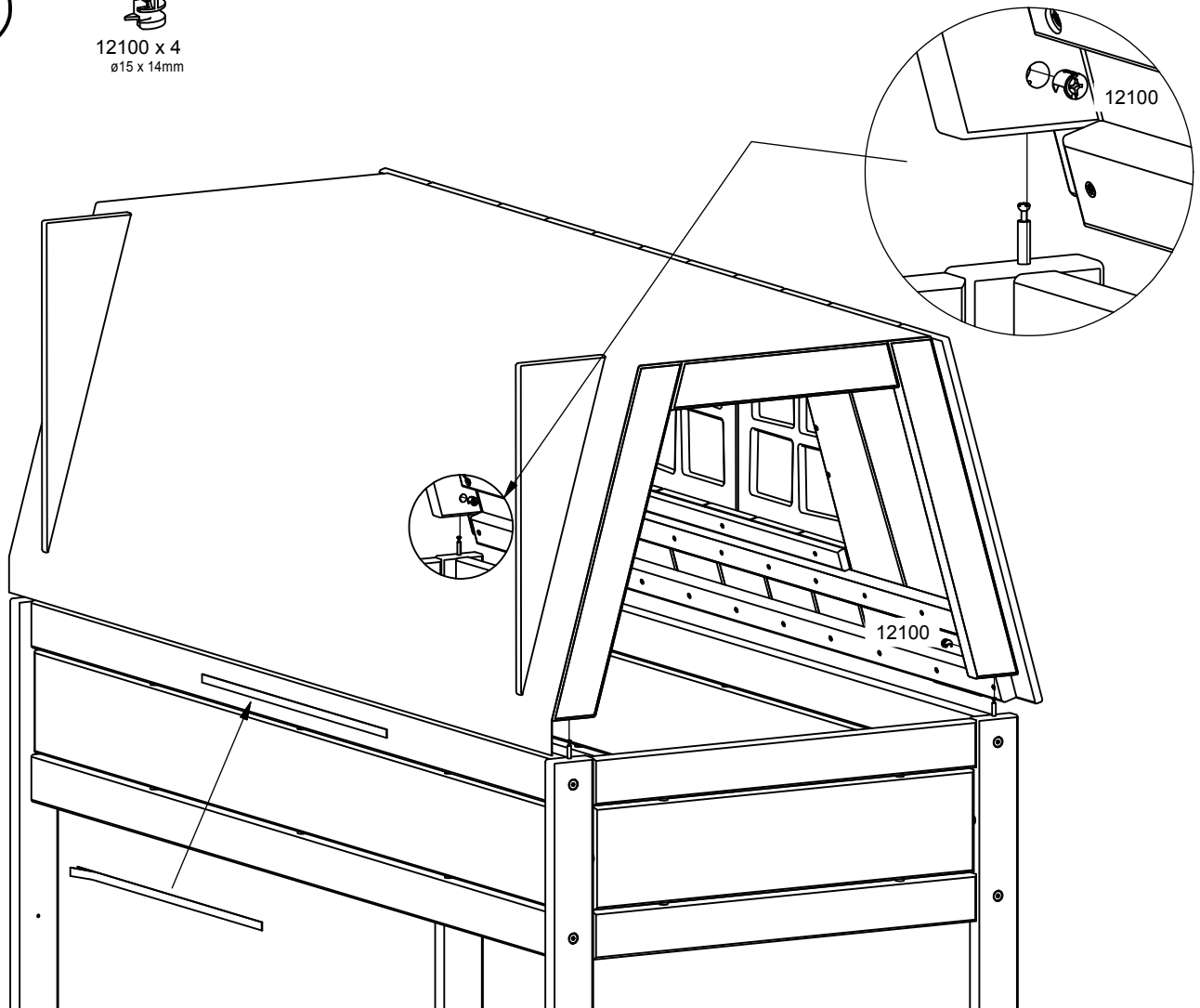

15



12899 L x 2



12899 R x 2

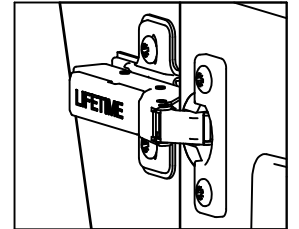
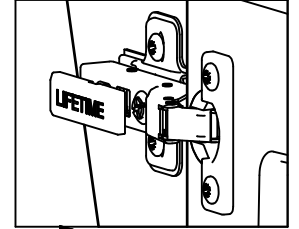
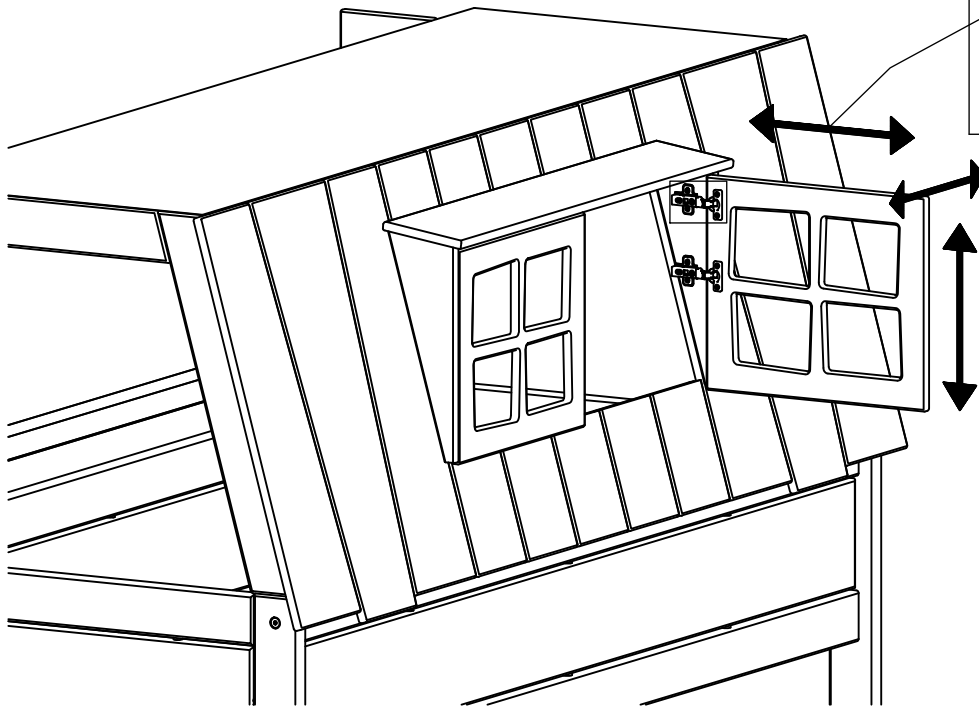
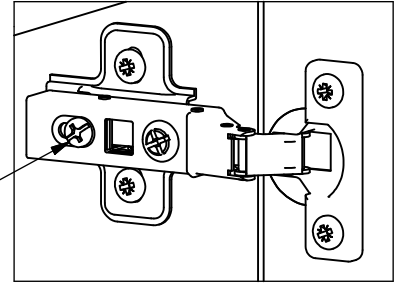

16



12460 x 14  
ø4 x 16mm



127711-01W x 6  
ø12 x 6mm



127711-02W x 8  
ø12 x 6mm



12623 x 1

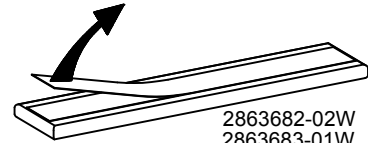

2863682-02W  
2863683-01W  
2863684-01W  
2863685-02W

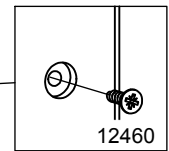
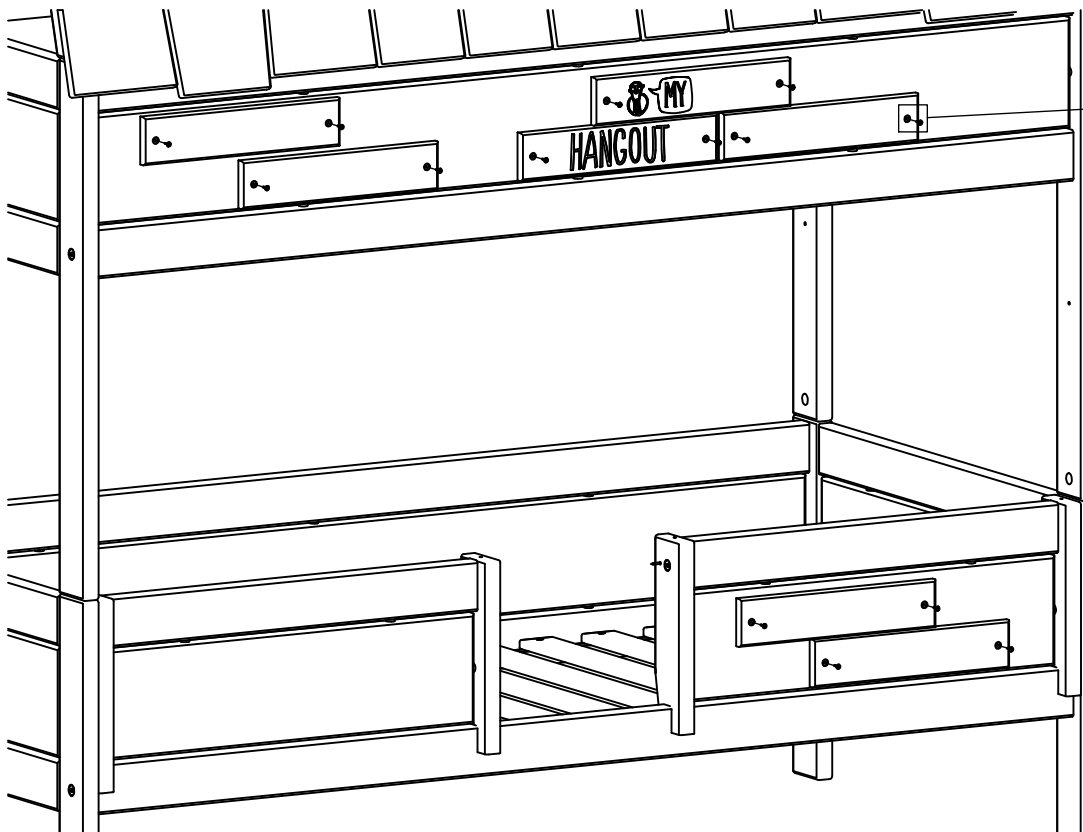

12460

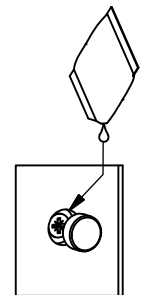

127711-01W  
127111-02W



**LIFETIME**  
KIDSROOMS

Samlevejledning  
Assembly Instructions  
Bauanleitung  
Montage handleiding  
Notice de montage  
Istruzioni di montaggio

**Art: 7060**

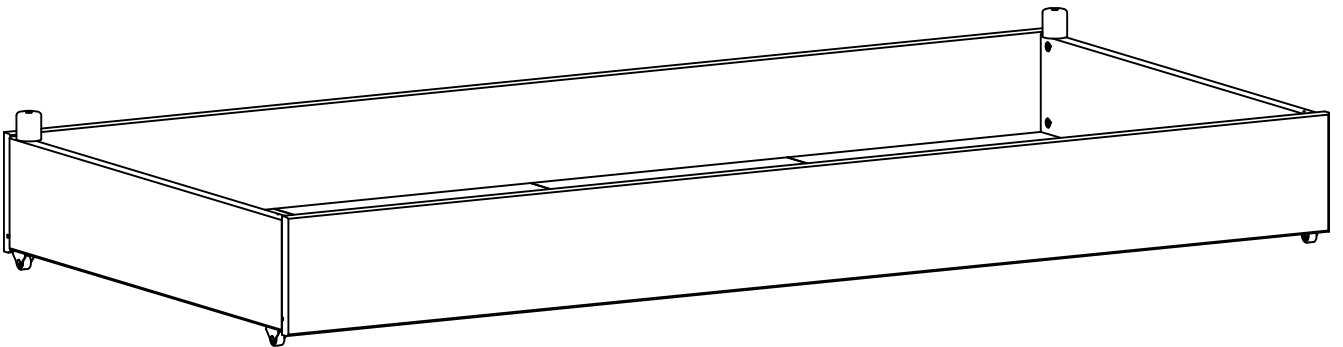

# VIGTIGT! IMPORTANT! WICHTIG! BELANGRIJK! IMPORTANTE! IMPORTANT!

- DK Før du starter. Læs venligst denne instruktion grundigt igennem og opbevar denne til evt senere brug. Sørg for at plastikposer ikke kommer i små børns hænder og vær sikker på, at der ikke er små børn i nærheden, under montagen, da der er små dele i pakken.
- UK Before you start. Please read instructions carefully and retain for future reference. Please dispose carefully of packing materials. Keep plastic bags away from young children. Ensure young children are kept clear during assembly as this pack contains small parts.
- D Bevor Sie anfangen lesen Sie bitte die Bauanleitung sorgfältig durch und bewahren Sie diese Anleitung auf. Versichern Sie sich, dass keine kleinen Kinder in der Nähe sind während Sie aufbauen weil die Verpackung kleinste Teile beinhaltet. Plastic Verpackungsteile daher bitte gleich wegwerfen.
- NL Voordat u begint, lees a.u.b. de montage-instructie aandachtig door en bewaar deze zorgvuldig. Plastic verpakkingsmateriaal weghouden bij jonge kinderen. Wees er zeker van dat tijdens het monteren van het bed de kinderen op veilige afstand zijn omdat de verpakking kleine onderdelen bevat.
- IT Prima di iniziare. Si prega di leggere attentamente le istruzioni e di conservarle per un uso successivo. Tenere lontano dalla portata dei bambini il pacchetto perché contiene piccole parti di assemblaggio e fare attenzione a non lasciarle in giro.
- F Avant de commencer. Veuillez lire cette notice soigneusement et pensez à la garder pour une utilisation ultérieure. Veuillez à ne pas laisser les sachets plastiques accessibles aux enfants, et à éloigner les enfants pendant le montage car présence de petits objets dans les colis.

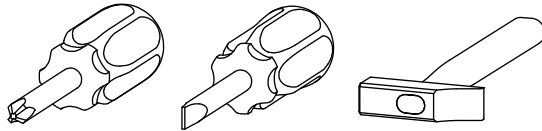
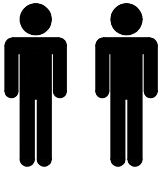

Art: 7060

Colli: 1

4070601

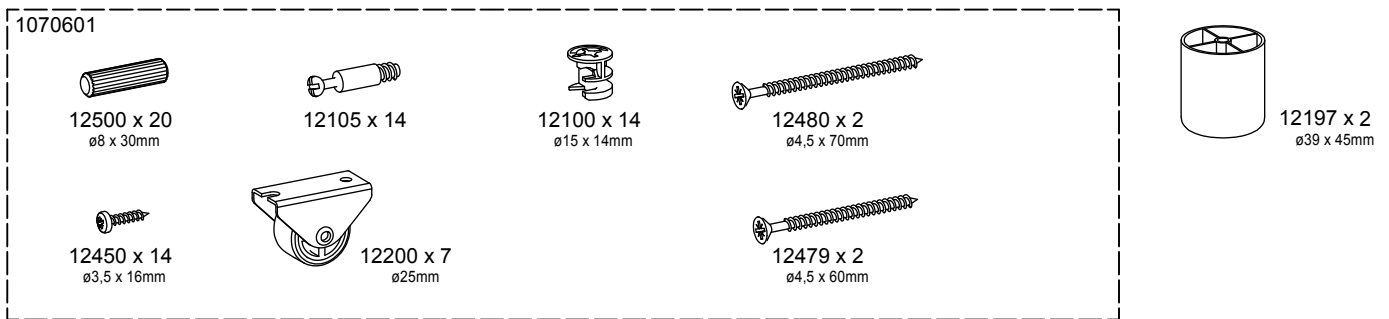

7060

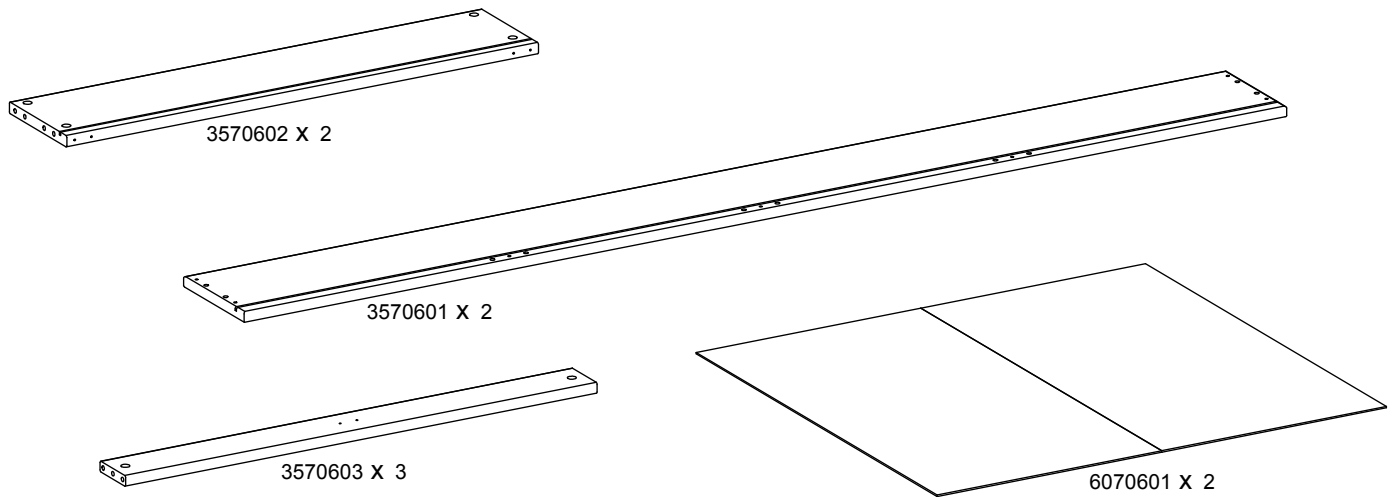

1

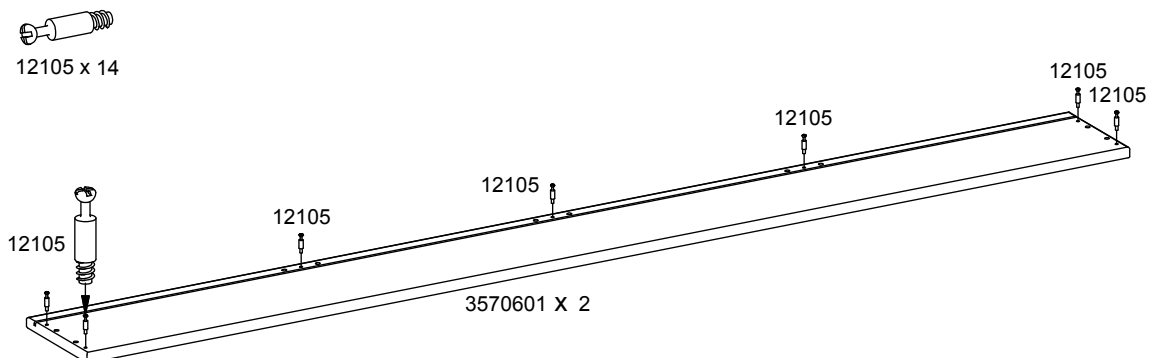



2

12500 x 20  
ø8 x 30mm

12450 x 14  
ø3,5 x 16mm

12200 x 7  
ø25mm

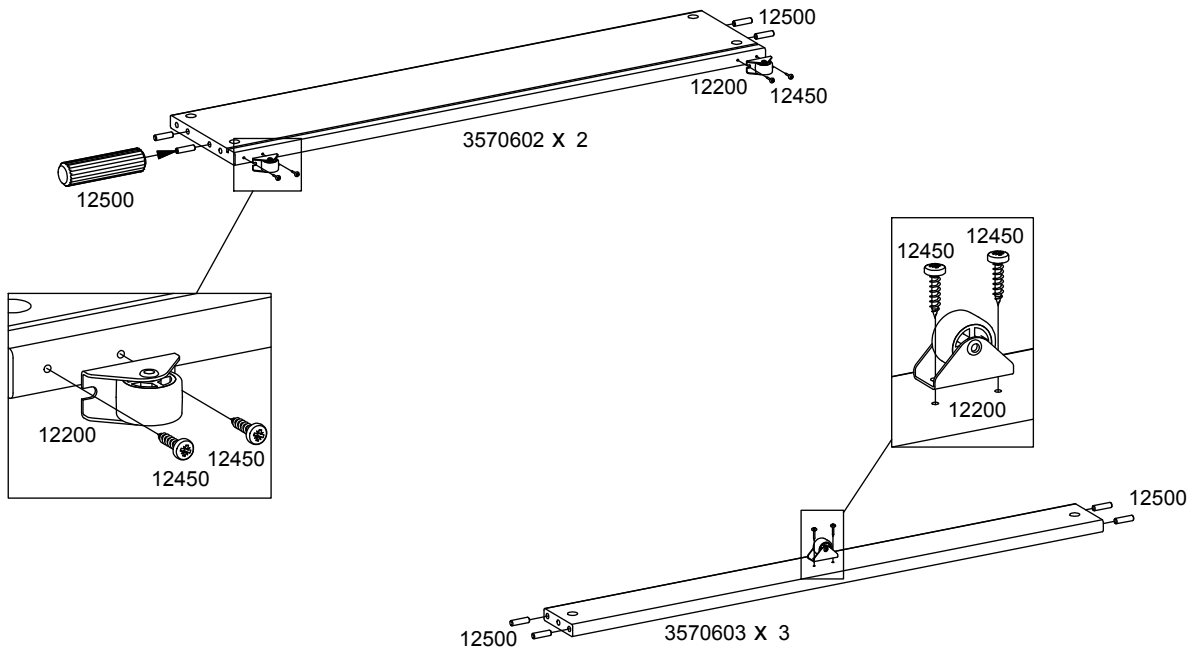

3

12100 x 7  
ø15 x 14mm

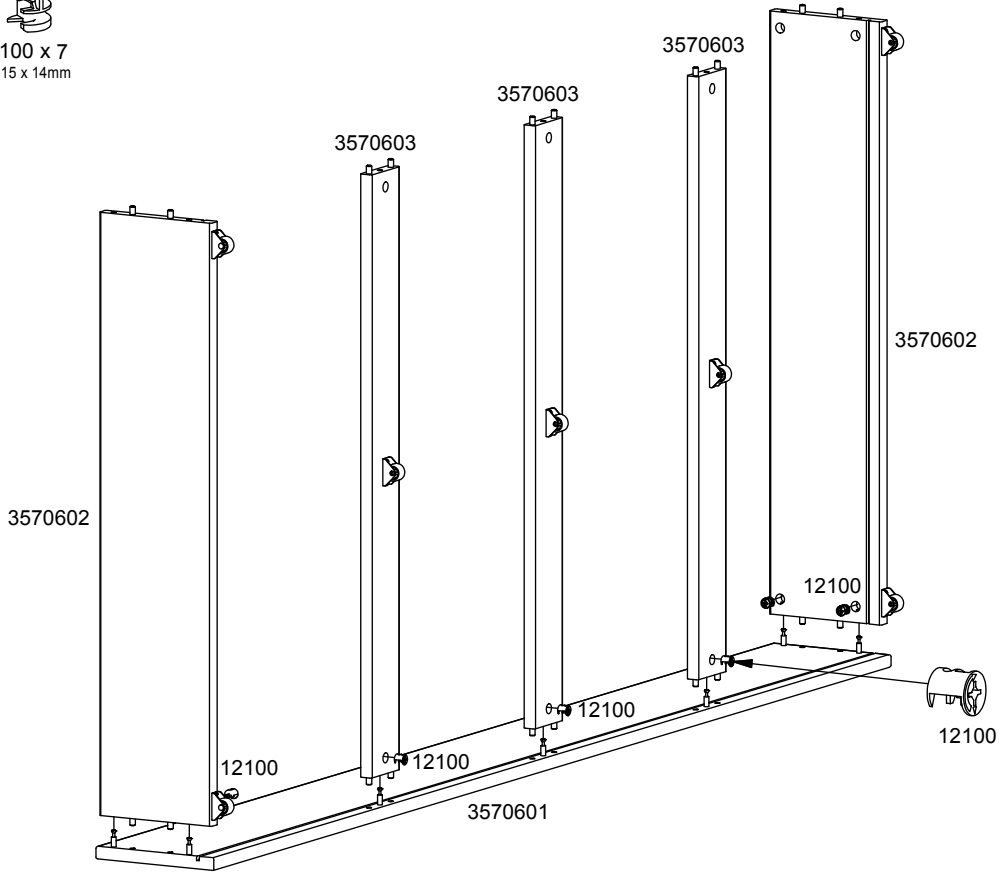

4

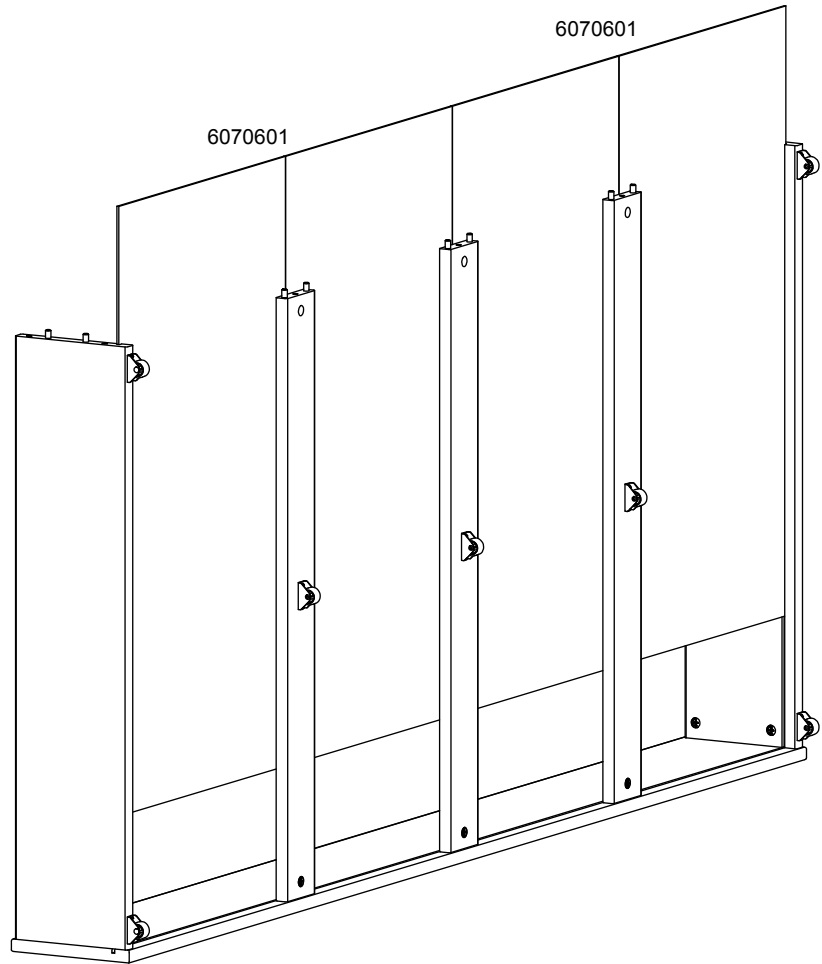

5

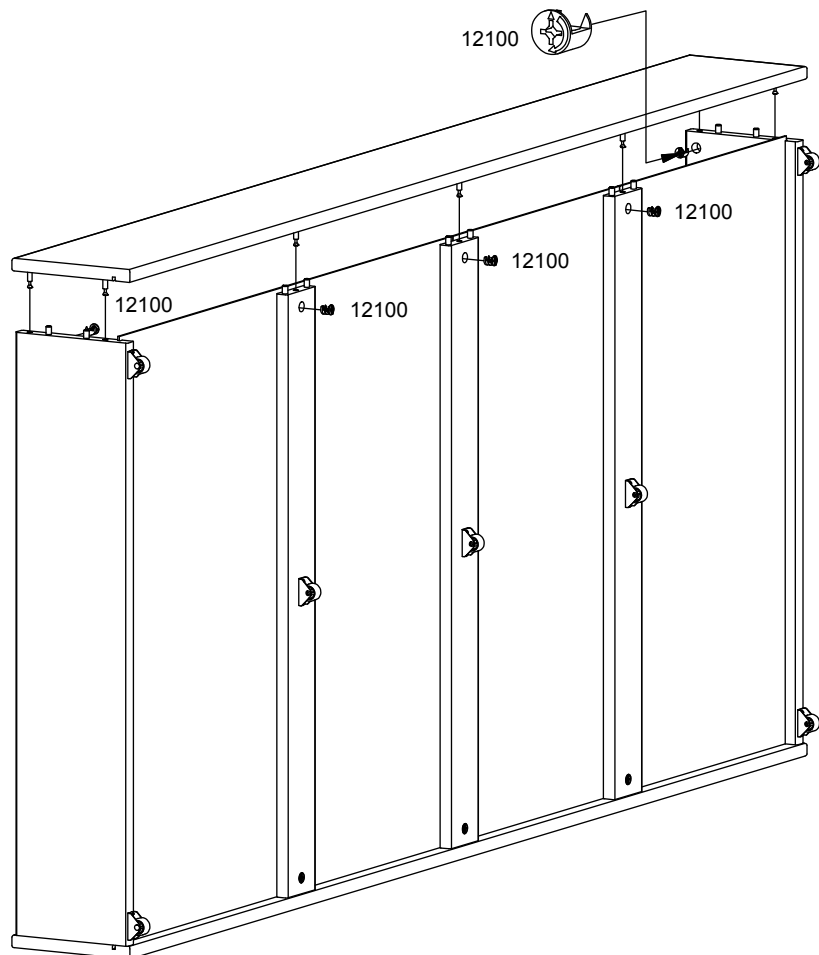

6.a

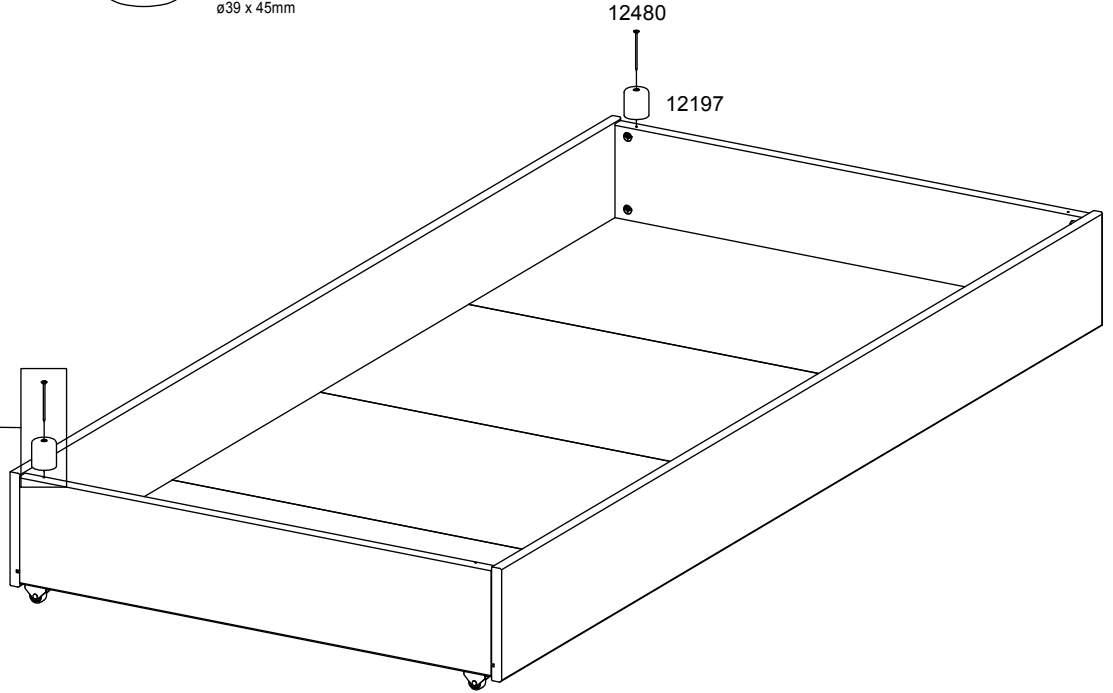
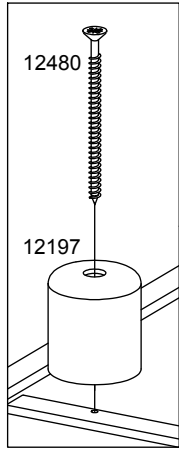
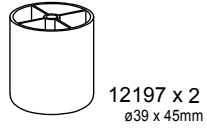

6.b

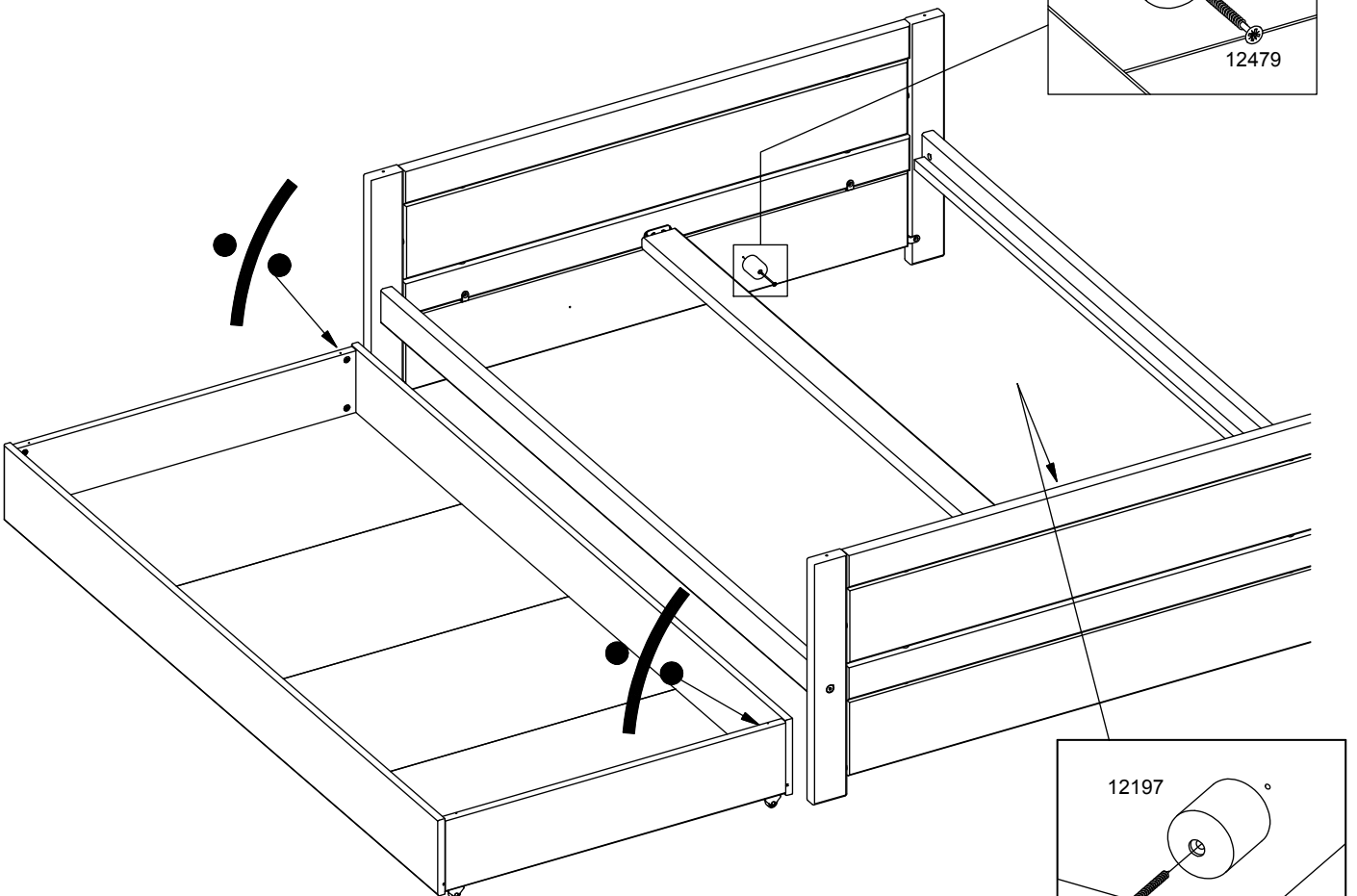
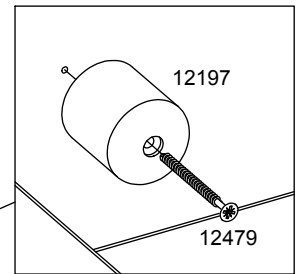
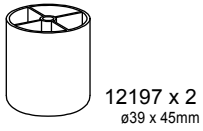

## DK I PLEJE OG SIKKERHED

**Det er vigtigt at denne vejledning bliver gemt til evt. senere brug. Læs omhyggeligt.**

Kontroller jævnligt at alle beslagene er fastspændte og at intet er beskadiget, så man ikke kan komme til skade.

Der må ikke bruges skuremiddel eller stærke rengøringsartikler til at rengøre produktet. Benyt en fugtig klud og tør efter med en tør klud.

Vær særlig opmærksom på flytning samt uforsigtig leg, kan medføre ødelæggelse af produktet og dermed skade barnet.

## UK I MAINTENANCE AND SAFETY

**It is important to save this information for later use. Read Carefully.**

Periodically check all fixings to ensure none have come loose and regularly inspect for damage which may cause injury.

Never clean your bookshelf with abrasive cleaners or strong detergents. Clean by wiping with a damp cloth and drying with a soft cloth.

## D I PFLEGE UND SICHERHEIT

**Wichtig ist, dass diese Anleitung für spätere Benutzung aufbewahrt wird.**

Kontrollieren Sie periodisch alle Beschläge um sicher zu sein, dass keine Beschläge lose sind und prüfen Sie regelmässig nach ob etwas Beschädigt ist, sodass niemand zu Schaden kommt.

Um das Regal zu reinigen, bitte keine Schleifmittel oder stärkere Reinigungsmittel benutzen. Sondern nehmen Sie ein feuchtes Tuch und trocknen Sie anschliessend mit einem trockenen weichen Tuch nach.

## NL I ONDERHOUD EN VEILIGHEID

**Belangrijk, zorgvuldig doorlezen en bewaren als naslagwerk.**

Controleer regelmatig alle bevestigingspunten om er zeker van te zijn dat er niets is losgeraakt. Controleer ook regelmatig op beschadigingen welke eventueel verwondingen kunnen veroorzaken.

Voor het schoonmaken van het boekenplank dient u GEEN gebruik te maken van agressieve of sterk zuiverende schoonmaakmiddelen. Gebruik alleen een vochtige doek en droog na met een zachte doek.

## IT I MANUTENZIONE E SICUREZZA

**E' importante leggere attentamente le istruzioni di seguito, per un corretto uso successivo del prodotto.**

Controllare regolarmente che tutti i componenti siano ben chiusi e che nulla sia danneggiato, per evitare di farsi male.

Non utilizzare detersivi abrasivi o aggressivi per pulire il prodotto. Usare un panno umido e asciugare con un panno asciutto.

## F I TRAITEMENT ET SECURITE

**Important de bien garder cette notice pour une utilisation ultérieure éventuelle. A lire minutieusement.**

Vérifier à intervalles réguliers que toutes les ferrures sont bien fixées et que rien n'est abimé afin de ne pas se blesser.

Ne pas utiliser de produits de nettoyage puissants ou à récurer. Utiliser un chiffon mouillé et sécher ensuite avec un chiffon sec.